

# Pipeline Valves

**API Specification 6D, Twenty-second Edition  
January 2002**

**ISO 14313: 1999, Petroleum and Natural Gas  
Industries—Pipeline Transportation Systems—  
Pipeline Valves**

EFFECTIVE DATE: JULY 1, 2002

PROPOSED NATIONAL ADOPTION



**Helping You  
Get The Job  
Done Right.<sup>SM</sup>**





## SPECIAL NOTES

API publications necessarily address problems of a general nature. With respect to particular circumstances, local, state, and federal laws and regulations should be reviewed.

API is not undertaking to meet the duties of employers, manufacturers, or suppliers to warn and properly train and equip their employees, and others exposed, concerning health and safety risks and precautions, nor undertaking their obligations under local, state, or federal laws.

Information concerning safety and health risks and proper precautions with respect to particular materials and conditions should be obtained from the employer, the manufacturer or supplier of that material, or the material safety data sheet.

Nothing contained in any API publication is to be construed as granting any right, by implication or otherwise, for the manufacture, sale, or use of any method, apparatus, or product covered by letters patent. Neither should anything contained in the publication be construed as insuring anyone against liability for infringement of letters patent.

Generally, API standards are reviewed and revised, reaffirmed, or withdrawn at least every five years. Sometimes a one-time extension of up to two years will be added to this review cycle. This publication will no longer be in effect five years after its publication date as an operative API standard or, where an extension has been granted, upon republication. Status of the publication can be ascertained from the API Upstream Segment telephone (202) 682-8000. A catalog of API publications and materials is published annually and updated quarterly by API, 1220 L Street, N.W., Washington, D.C. 20005.

This document was produced under API standardization procedures that ensure appropriate notification and participation in the developmental process and is designated as an API standard. Questions concerning the interpretation of the content of this standard or comments and questions concerning the procedures under which this standard was developed should be directed in writing to the director/general manager of the Upstream Segment, American Petroleum Institute, 1220 L Street, N.W., Washington, D.C. 20005. Requests for permission to reproduce or translate all or any part of the material published herein should also be addressed to the director.

API standards are published to facilitate the broad availability of proven, sound engineering and operating practices. These standards are not intended to obviate the need for applying sound engineering judgment regarding when and where these standards should be utilized. The formulation and publication of API standards is not intended in any way to inhibit anyone from using any other practices.

Any manufacturer marking equipment or materials in conformance with the marking requirements of an API standard is solely responsible for complying with all the applicable requirements of that standard. API does not represent, warrant, or guarantee that such products do in fact conform to the applicable API standard.

**API FOREWORD**

This standard is under the jurisdiction of the API Standards Subcommittee on Valves and Wellhead Equipment (API C1/SC6). This API standard is identical with the English version of ISO 14313:1999. ISO 14313 was prepared by Technical Committee ISO/TC 67 *Materials, equipment and offshore structures for petroleum and natural gas industries, SC 2, Pipeline transportation systems*.

For the purposes of this standard, the following editorial changes have been made:

- a) *Deletion of ISO Forward from the international standard, replaced by API Special Notes and Forward;*
- b) *A national informative annex (Annex E—API Monogram) has been included giving guidance to users.*

This standard shall become effective on the date printed on the cover but may be used voluntarily from the date of distribution.

API publications may be used by anyone desiring to do so. Every effort has been made by the Institute to assure the accuracy and reliability of the data contained in them; however, the Institute makes no representation, warranty, or guarantee in connection with this publication and hereby expressly disclaims any liability or responsibility for loss or damage resulting from its use or for the violation of any federal, state, or municipal regulation with which this publication may conflict.

Suggested revisions are invited and should be submitted to the Upstream Segment, API, 1220 L Street, NW, Washington, D.C. 20005.

**Contents**

**1 Scope..... 1**

**2 Normative references..... 1**

**3 Terms and definitions..... 3**

**4 Symbols and abbreviations ..... 6**

**4.1 Symbols..... 6**

**4.2 Abbreviations ..... 6**

**5 Valve types and configurations ..... 7**

**5.1 Valve types..... 7**

**5.2 Valve configurations ..... 7**

**6 Design..... 19**

**6.1 Pressure and temperature rating..... 19**

**6.2 Sizes..... 20**

**6.3 Face-to-face and end-to-end dimensions..... 20**

**6.4 Minimum-bore full-opening valves..... 33**

**6.5 Valve operation ..... 33**

**6.6 Pigging..... 33**

**6.7 Valve ends..... 34**

**6.8 Pressure relief..... 34**

**6.9 Bypass, drain and vent connections ..... 34**

**6.10 Handwheels and wrenches (levers)..... 35**

**6.11 Locking devices..... 35**

6.12 Position indicators..... 35

6.13 Operators and stem extensions..... 36

6.14 Sealant injection..... 36

6.15 Lifting lugs ..... 36

6.16 Actuators..... 36

6.17 Drive trains ..... 36

6.18 Stem retention..... 37

6.19 Fire safety..... 37

6.20 Anti-static device..... 37

6.21 Design documents..... 37

6.22 Design document review..... 37

7 Materials..... 37

7.1 Material specification..... 37

7.2 Service compatibility..... 37

7.3 Forged parts..... 38

7.4 Welding ends..... 38

7.5 Toughness test requirements..... 38

7.6 Bolting..... 39

7.7 Sour service ..... 39

8 Welding..... 39

8.1 Qualifications..... 39

8.2 Impact testing ..... 39

8.3 Hardness testing..... 40

9 Quality control ..... 41

9.1 General ..... 41

9.2 Measuring and test equipment..... 42

9.3 Qualification of inspection and test personnel ..... 42

9.4 NDE of repair welding..... 42

10 Pressure testing ..... 43

10.1 General ..... 43

**10.2 Stem backseat test..... 43**

**10.3 Hydrostatic shell test ..... 44**

**10.4 Hydrostatic seat test ..... 44**

**10.5 Draining ..... 46**

**11 Marking..... 46**

**11.1 Requirements ..... 46**

**11.2 Marking example..... 49**

**12 Storage and shipping ..... 50**

**12.1 Painting..... 50**

**12.2 Corrosion prevention..... 50**

**12.3 Openings ..... 50**

**13 Documentation..... 50**

**Annex A (informative) Purchasing guidelines..... 51**

**Annex B (normative) Supplementary NDE requirements..... 53**

**Annex C (normative) Supplementary test requirements ..... 57**

**Annex D (normative) Supplementary documentation requirements..... 61**

**Annex E (informative) API Monogram..... 63**

**Bibliography ..... 65**

## **Introduction**

This International Standard is based on API Specification 6D, twenty-first edition, March 1994.

Users of this International Standard should be aware that further or differing requirements may be needed for individual applications. This International Standard is not intended to inhibit a vendor from offering, or the purchaser from accepting, alternative equipment or engineering solutions for the individual application. This may be particularly applicable where there is innovative or developing technology. Where an alternative is offered, the vendor should identify any variations from this International Standard and provide details.



# Petroleum and natural gas industries— Pipeline transportation systems—Pipeline valves

## 1 Scope

This International Standard specifies requirements and gives recommendations for the design, manufacturing, testing and documentation of ball, check, gate and plug valves for application in pipeline systems meeting the requirements of ISO 13623 for the petroleum and natural gas industries.

Valves for pressure ratings exceeding PN 420 (Class 2500) are not covered by this International Standard.

Annex A of this International Standard provides guidelines to assist the purchaser with valve type selection and specification of specific requirements when ordering valves.

## 2 Normative references

The following normative documents contain provisions which, through reference in this text, constitute provisions of this International Standard. For dated references, subsequent amendments to, or revisions of, any of these publications do not apply. However, parties to agreements based on this International Standard are encouraged to investigate the possibility of applying the most recent editions of the normative documents indicated below. For undated references, the latest edition of the normative document referred to applies. Members of ISO and IEC maintain registers of currently valid International Standards.

NOTE Non-International Standards may be replaced, by agreement, with other recognized and equivalent national or industry standards.

ISO 7-1, *Pipe threads where pressure-tight joints are made on the threads—Part 1: Dimensions, tolerances and designation.*

ISO 148, *Steel — Charpy impact test (V-notch).*

ISO 228-1, *Pipe threads where pressure-tight joints are not made on the threads—Part 1: Dimensions, tolerances and designation.*

ISO 228-2, *Pipe threads where pressure-tight joints are not made on the threads—Part 2: Verification by means of limit gauges.*

ISO 5208, *Industrial valves—Pressure testing of valves.*

ISO 7005-1, *Metallic flanges—Part 1: Steel flanges.*

ISO 10474, *Steel and steel products—Inspection documents.*

ISO 10497, *Testing of valves—Fire type-testing requirements.*

ISO 13623, *Petroleum and natural gas industries—Pipeline transportation systems.*

ASME B1.1, *Unified inch screw threads (UN and UNR thread form).*

ASME B1.20.1, *Pipe threads, General purpose (inch)*.

ASME B16.5, *Pipe flanges and flanged fittings—NPS 1/2 through NPS 24*.

ASME B16.10, *Face-to-face and end-to-end dimensions of valves*.

ASME B16.25:1997, *Buttwelding ends*.

ASME B16.34:1996, *Valves—Flanged, threaded, and welding end*.

ASME B16.47, *Larger diameter steel flanges—NPS 26 through NPS 60*.

ASME B31.4:1992, *Liquid transportation systems for hydrocarbons, liquid petroleum gas, anhydrous ammonia, and alcohols*.

ASME B31.8:1995, *Gas transmission and distribution piping systems*.

ASME Boiler and Pressure Vessel Code:1998, Section V, *Non destructive examination*.

ASME Boiler and Pressure Vessel Code:1998, Section VIII, Division 1, *Rules for construction of pressure vessels*.

ASME Boiler and Pressure Vessel Code:1998, Section VIII, Division 2, *Alternative rules for construction of pressure vessels*.

ASME Boiler and Pressure Vessel Code, Section IX, *Qualification standard for welding and brazing procedures, welders, brazers, and welding and brazing operators*.

(American Society of Mechanical Engineers, 345 East 47<sup>th</sup> Street, New York 10017-2392, USA)

ASNT SNT-TC-1A, *Recommended Practice No. SNT-TC-1A*.

(American Society of Non-Destructive Testing, P.O. Box 28518, 1711 Arlingate Lane, Columbus, Ohio 43228-0518, USA)

ASTM A 193/A 193M, *Standard specification for alloy-steel and stainless steel bolting materials for high-temperature service*.

ASTM A 320/A 320M, *Standard specification for alloy steel bolting materials for low-temperature service*.

ASTM A 370, *Standard test methods and definitions for mechanical testing of steel products*.

ASTM A 388/A 388M, *Standard practice for ultrasonic examination of heavy steel forgings*.

ASTM A 435/A 435M, *Standard specification for straight-beam ultrasonic examination of steel plates*.

ASTM A 577/A 577M, *Standard specification for ultrasonic angle-beam examination of steel plates*.

ASTM A 609/A 609M:1997, *Standard practice for castings, carbon, low-alloy, and martensitic stainless steel, ultrasonic examination thereof*.

(American Society for Testing and Materials, 100 Barr Harbor Drive, West Conshohocken, Pennsylvania 19428-2959, USA)

AWS QC1, *Standard for AWS certification of welding inspectors*.

(The American Welding Society, 550 NW LeJeune Road, Miami, Florida 33126, USA)

EN 287-1, *Approval testing of welders—Fusion welding—Part 1: Steels*.

EN 288-3, *Specification and approval of welding procedures for metallic materials—Part 3: Welding procedure tests for the arc welding of steels*.

EN 473:1993, *Qualification and certification of NDT personnel—General principles.*

(CEN, European Committee for Standardization, Central Secretariat, Rue de Stassart 36, B-1050, Brussels, Belgium)

MSS SP-44, *Steel pipeline flanges.*

(Manufacturers Standardization Society of the Valve & Fittings Industry Inc., 127 Park Street N.E., Vienna, Virginia 22180, USA)

NACE MR 0175, *Sulfide stress cracking resistant metallic materials for oilfield equipment.*

NACE TM 0177, *Laboratory testing of metals for resistance to specific forms of environmental cracking in H<sub>2</sub>S environments.*

NACE TM 0284, *Evaluation of pipeline and pressure vessel steels for resistance to hydrogen-induced cracking.*

(National Association of Corrosion Engineers, P.O. Box 218340, Houston, Texas 77218, USA)

### 3 Terms and definitions

For the purposes of this International Standard, the following terms and definitions apply:

#### 3.1

##### **ANSI rating class**

numerical pressure design class defined in ASME B16.5 and used for reference purposes

NOTE The ANSI rating class is designated by the word "Class" followed by a number.

#### 3.2

##### **bi-directional valve**

valve designed for blocking the fluid in both downstream and upstream directions

#### 3.3

##### **bleed**

drain or vent

#### 3.4

##### **block valve**

gate, plug or ball valve that blocks flow into the downstream conduit when in the closed position

NOTE Valves are either single- or double-seated, bi-directional or uni-directional.

#### 3.5

##### **breakaway thrust**

##### **breakaway torque**

thrust or torque required for opening a valve with maximum pressure differential

#### 3.6

##### **by agreement**

agreed between manufacturer and purchaser

#### 3.7

##### **double-block-and-bleed (DBB) valve**

valve with two seating surfaces which, in the closed position, blocks flow from both valve ends when the cavity between the seating surfaces is vented through a bleed connection provided on the body cavity

#### 3.8

##### **drive train**

all parts of a valve drive between the operator and the obturator, including the obturator but excluding the operator

**3.9****flow coefficient**

$K_v$   
volumetric flow rate, in cubic metres per hour, of water at a temperature between 5°C (40°F) and 40°C (104°F) passing through a valve and resulting in a pressure loss of 1 bar (14,7 psi)

NOTE  $K_v$  relates to the flow coefficient  $C_v$  in US gallons per minute at 15,6°C (60°F) resulting in a 1 psi pressure drop as follows:

$$K_v = \frac{C_v}{1,156}$$

**3.10****full-opening valve**

valve with an unobstructed opening capable of allowing a sphere or other internal device for the same nominal size as the valve to pass

**3.11****handwheel**

wheel consisting of a rim connected to a hub, for example, by spokes, and used to operate manually a valve requiring multiple turns

**3.12****locking device**

part or an arrangement of parts for securing a valve in the open and/or closed position

**3.13****manual actuator****manual operator**

wrench (lever) or handwheel with or without a gearbox

**3.14****maximum pressure differential (MPD)**

maximum difference between the upstream and downstream pressure across the obturator at which the obturator may be operated

**3.15****nominal pipe size (NPS)**

numerical inches designation of size which is common to components in piping systems of any one size

NOTE The nominal pipe size is designated by the letters NPS followed by a number.

**3.16****nominal pressure (PN) class**

numerical pressure design class as defined in ISO 7005-1 and used for reference purposes

NOTE The nominal pressure (PN) class is designated by the abbreviation PN followed by a number.

**3.17****nominal size (DN)**

numerical metric designation of size which is common to components in piping systems of any one size

NOTE Nominal size is designated by the letters DN followed by a number.

**3.18****obturator****closure member**

part of a valve, such as a ball, clapper, disc, gate or plug, which is positioned in the flow stream to permit or block flow

**3.19****operator**

device (or assembly) for opening or closing a valve

**3.20**

**position indicator**

device to show the position of the valve obturator

**3.21**

**powered actuator**

**powered operator**

electric, hydraulic or pneumatic device bolted or otherwise attached to the valve for powered opening and closing of the valve

**3.22**

**pressure class**

numerical pressure design class expressed in accordance with either the nominal pressure (PN) class or the ANSI rating class

NOTE In this International Standard, the pressure class is stated by the PN class followed by the ANSI rating class between brackets.

**3.23**

**pressure-containing parts**

parts, such as bodies, bonnets, glands, stems, gaskets and bolting, designed to contain the pipeline fluid

**3.24**

**pressure-controlling parts**

parts, such as seat and obturator, intended to block or permit the flow of fluids

**3.25**

**process-wetted parts**

parts exposed directly to the pipeline fluid

**3.26**

**reduced-opening valve**

valve with the opening through the obturator smaller than at the end connection(s)

**3.27**

**seating surfaces**

contact surfaces of the obturator and seat which ensure valve sealing

**3.28**

**stem**

part that connects the obturator to the operator and which may consist of one or more components

**3.29**

**stem extension assembly**

assembly consisting of the stem extension and the stem extension housing

**3.30**

**support ribs or legs**

metal structure which provides a stable footing when the valve is set on a fixed base

**3.31**

**through-conduit valve**

valve with an unobstructed and continuous cylindrical opening

**3.32**

**twin-seat, both seats bi-directional, valve**

valve with two seats, each sealing in both directions

**3.33****twin-seat, one seat uni-directional and one seat bi-directional, valve**

valve with two seats, one sealing in one direction and the other in either direction

**3.34****uni-directional valve**

valve designed for blocking the flow in one direction only

**3.35****venturi plug valve**

valve with a substantially reduced opening through the plug and a smooth transition from each full-opening end to the reduced opening

**4 Symbols and abbreviations****4.1 Symbols**

$C_v$  Flow coefficient in imperial units

$K_v$  Flow coefficient in metric units

**4.2 Abbreviations**

|      |                                  |
|------|----------------------------------|
| BM   | Base metal                       |
| CE   | Carbon equivalent                |
| DBB  | Double-block-and-bleed           |
| DN   | Nominal size                     |
| HAZ  | Heat-affected zone               |
| HR   | Rockwell hardness                |
| HV   | Vickers hardness                 |
| MPD  | Maximum pressure differential    |
| MT   | Magnetic-particle testing        |
| NDE  | Non-destructive examination      |
| NPS  | Nominal pipe size                |
| PN   | Nominal pressure                 |
| PQR  | Procedure qualification record   |
| PT   | Penetrant testing                |
| PWHT | Post-weld heat treatment         |
| SMYS | Specified minimum yield strength |
| WM   | Weld metal                       |
| WPS  | Weld procedure specification     |
| WQR  | Welder qualification record      |

## 5 Valve types and configurations

### 5.1 Valve types

#### 5.1.1 Gate valves

Typical configurations for gate valves with flanged and welding ends are shown, for illustration purposes only, in Figures 1 and 2.

Gate valves shall have an obturator which moves in a plane perpendicular to the direction of flow. The gate can be constructed of one piece for slab-gate valves or of two or more pieces for expanding-gate valves.

Gate valves shall be provided with a back seat or secondary stem sealing feature in addition to the primary stem seal.

#### 5.1.2 Lubricated and non-lubricated plug valves

Typical configurations for plug valves with flanged and welding ends are shown, for illustration purposes only, in Figure 3.

Plug valves shall have a cylindrical or conical obturator which rotates about an axis perpendicular to the direction of flow.

#### 5.1.3 Ball valves

Typical configurations for ball valves with flanged or welding ends are shown, for illustration purposes only, in Figures 4, 5 and 6.

Ball valves shall have a spherical obturator which rotates on an axis perpendicular to the direction of flow.

#### 5.1.4 Check valves

Typical configurations for check valves are shown, for illustration purposes only, in Figures 7 to 11. Check valves may also be of the wafer type.

Check valves shall have an obturator which responds automatically to block fluid in one direction.

### 5.2 Valve configurations

#### 5.2.1 Full-opening valves

Full-opening valves shall be unobstructed in the fully opened position and have an internal bore as specified in Table 1. There is no restriction on the upper limit of valve bore sizes.

Full-opening through-conduit valves shall have a circular bore in the obturator that will allow a sphere with a nominal size not less than that specified in Table 1 to pass.

Welding-end valves may require a smaller bore at the welding end to mate with the pipe.

#### 5.2.2 Reduced-opening valves

The internal bore of reduced-opening valves shall be less than the internal bore specified in Table 1.

Table 1—Minimum bore for full-opening valves (mm)

| DN<br>(mm) | NPS<br>(inches) | Pressure class                     |                       |                        |                        |
|------------|-----------------|------------------------------------|-----------------------|------------------------|------------------------|
|            |                 | PN 20 to 100<br>(Class 150 to 600) | PN 150<br>(Class 900) | PN 250<br>(Class 1500) | PN 420<br>(Class 2500) |
| 15         | 1/2             | 13                                 | 13                    | 13                     | 13                     |
| 20         | 3/4             | 19                                 | 19                    | 19                     | 19                     |
| 25         | 1               | 25                                 | 25                    | 25                     | 25                     |
| 32         | 1 1/4           | 32                                 | 32                    | 32                     | 32                     |
| 40         | 1 1/2           | 38                                 | 38                    | 38                     | 38                     |
| 50         | 2               | 49                                 | 49                    | 49                     | 42                     |
| 65         | 2 1/2           | 62                                 | 62                    | 62                     | 52                     |
| 80         | 3               | 74                                 | 74                    | 74                     | 62                     |
| 100        | 4               | 100                                | 100                   | 100                    | 87                     |
| 150        | 6               | 150                                | 150                   | 144                    | 131                    |
| 200        | 8               | 201                                | 201                   | 192                    | 179                    |
| 250        | 10              | 252                                | 252                   | 239                    | 223                    |
| 300        | 12              | 303                                | 303                   | 287                    | 265                    |
| 350        | 14              | 334                                | 322                   | 315                    | —                      |
| 400        | 16              | 385                                | 373                   | 360                    | —                      |
| 450        | 18              | 436                                | 423                   | —                      | —                      |
| 500        | 20              | 487                                | 471                   | —                      | —                      |
| 550        | 22              | 538                                | 522                   | —                      | —                      |
| 600        | 24              | 589                                | 570                   | —                      | —                      |
| 650        | 26              | 633                                | 617                   | —                      | —                      |
| 700        | 28              | 684                                | 665                   | —                      | —                      |
| 750        | 30              | 735                                | 712                   | —                      | —                      |
| 800        | 32              | 779                                | 760                   | —                      | —                      |
| 850        | 34              | 830                                | 808                   | —                      | —                      |
| 900        | 36              | 874                                | 855                   | —                      | —                      |
| 950        | 38              | 925                                | —                     | —                      | —                      |
| 1 000      | 40              | 976                                | —                     | —                      | —                      |
| 1 050      | 42              | 1 020                              | —                     | —                      | —                      |
| 1 200      | 48              | 1 166                              | —                     | —                      | —                      |
| 1 350      | 54              | 1 312                              | —                     | —                      | —                      |
| 1 400      | 56              | 1 360                              | —                     | —                      | —                      |
| 1 500      | 60              | 1 458                              | —                     | —                      | —                      |



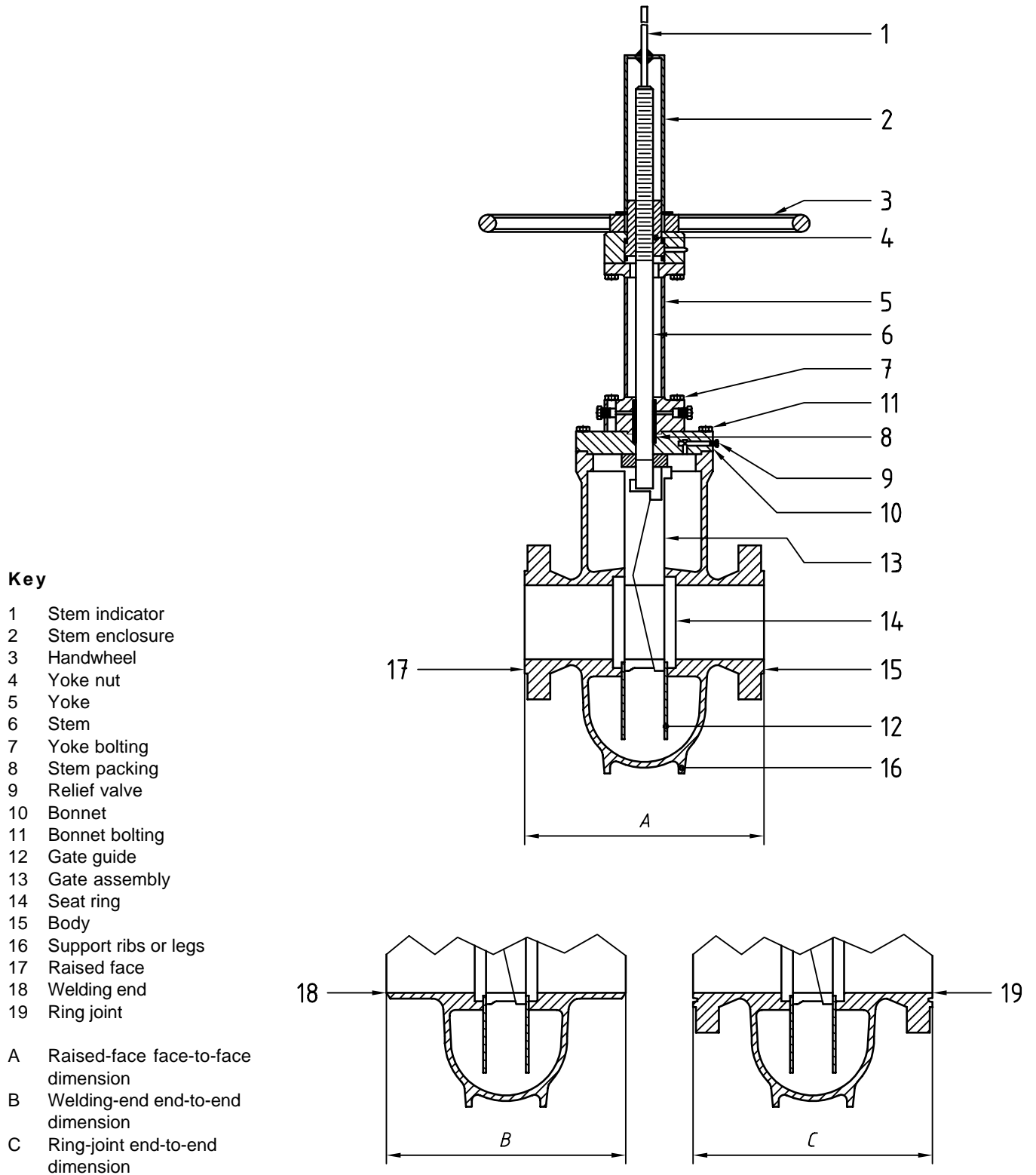

Figure 1—Expanding-gate/rising-stem gate valve

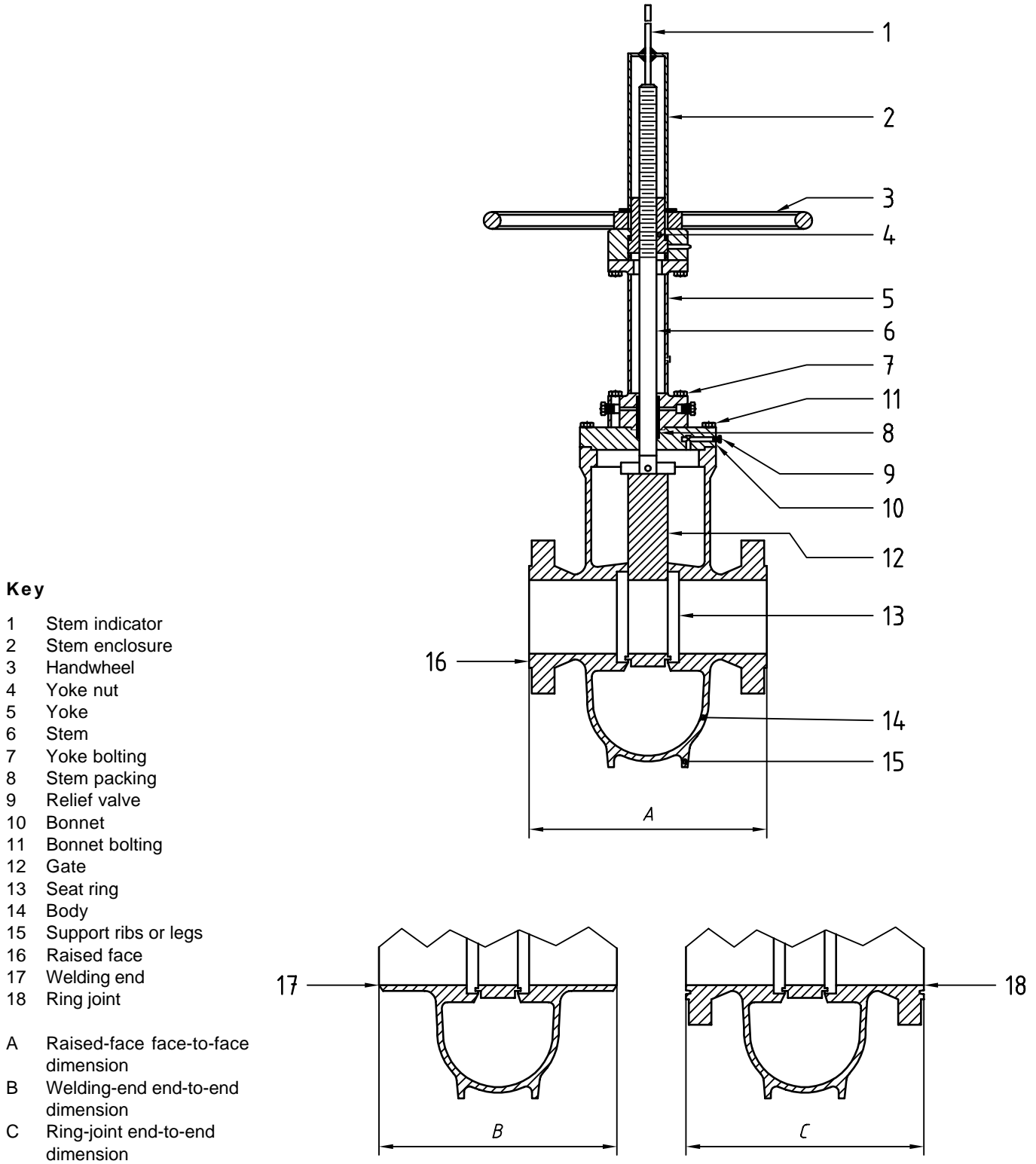
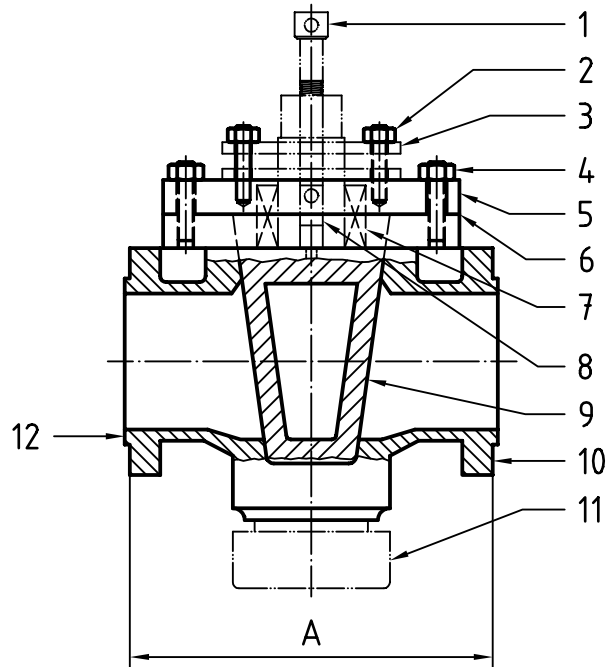
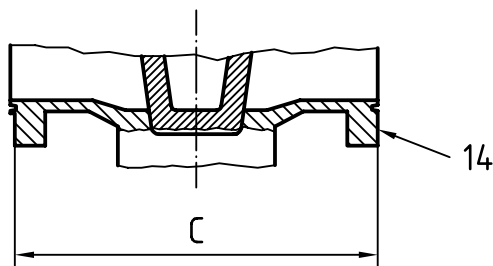
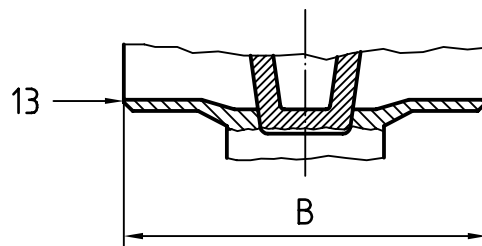

Figure 2—Slab-gate/through-conduit rising-stem gate valve



**Key**

- 1 Lubricator screw
- 2 Gland studs and nuts
- 3 Gland
- 4 Cover studs and nuts
- 5 Cover
- 6 Cover gasket
- 7 Stem packing
- 8 Lubricant check valve
- 9 Plug
- 10 Body
- 11 Stop collar
- 12 Raised face
- 13 Welding end
- 14 Ring joint



- A Raised-face face-to-face dimension
- B Welding-end end-to-end dimension
- C Ring-joint end-to-end dimension

**Figure 3—Plug valve**

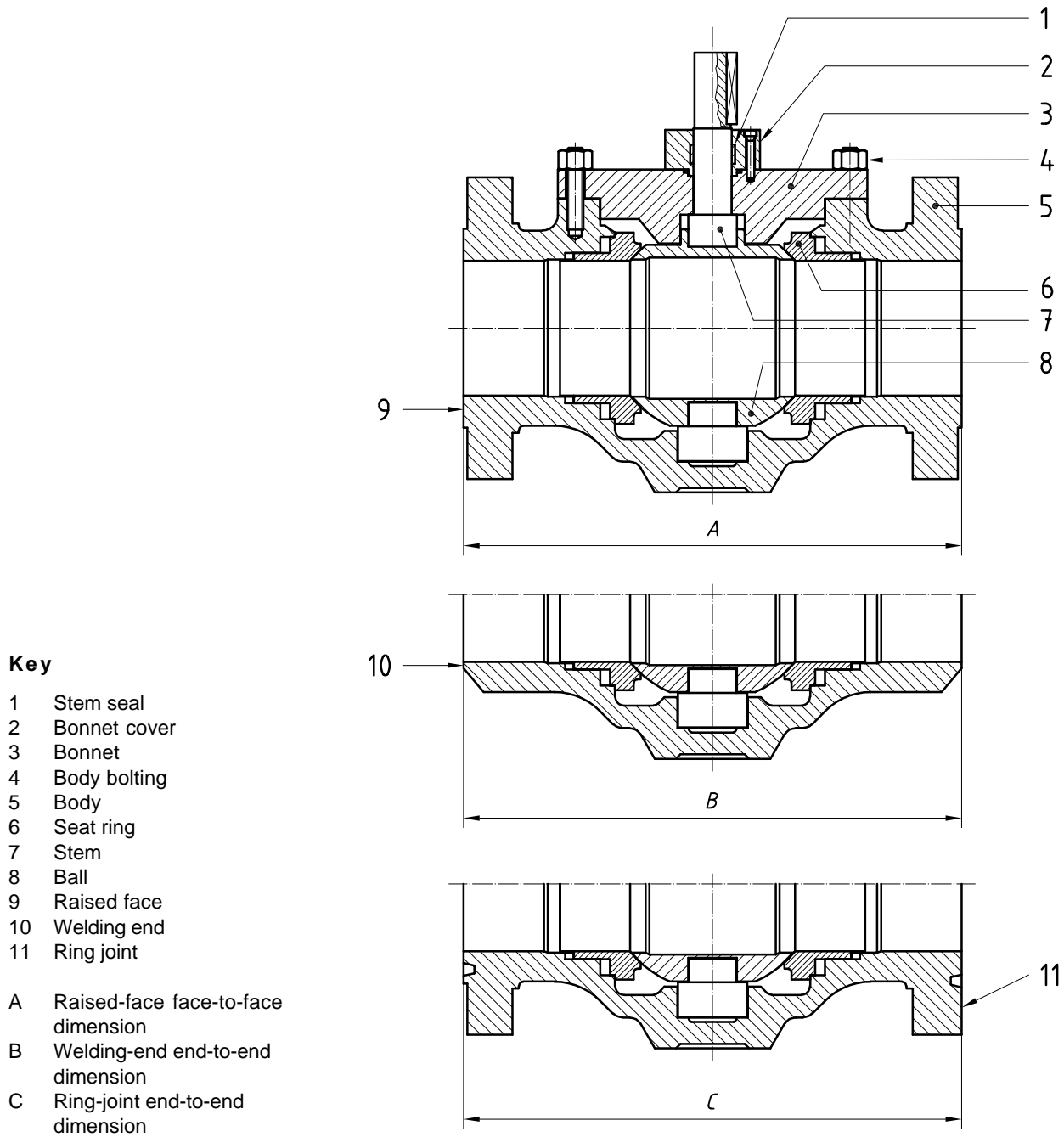

Figure 4—Top-entry ball valve

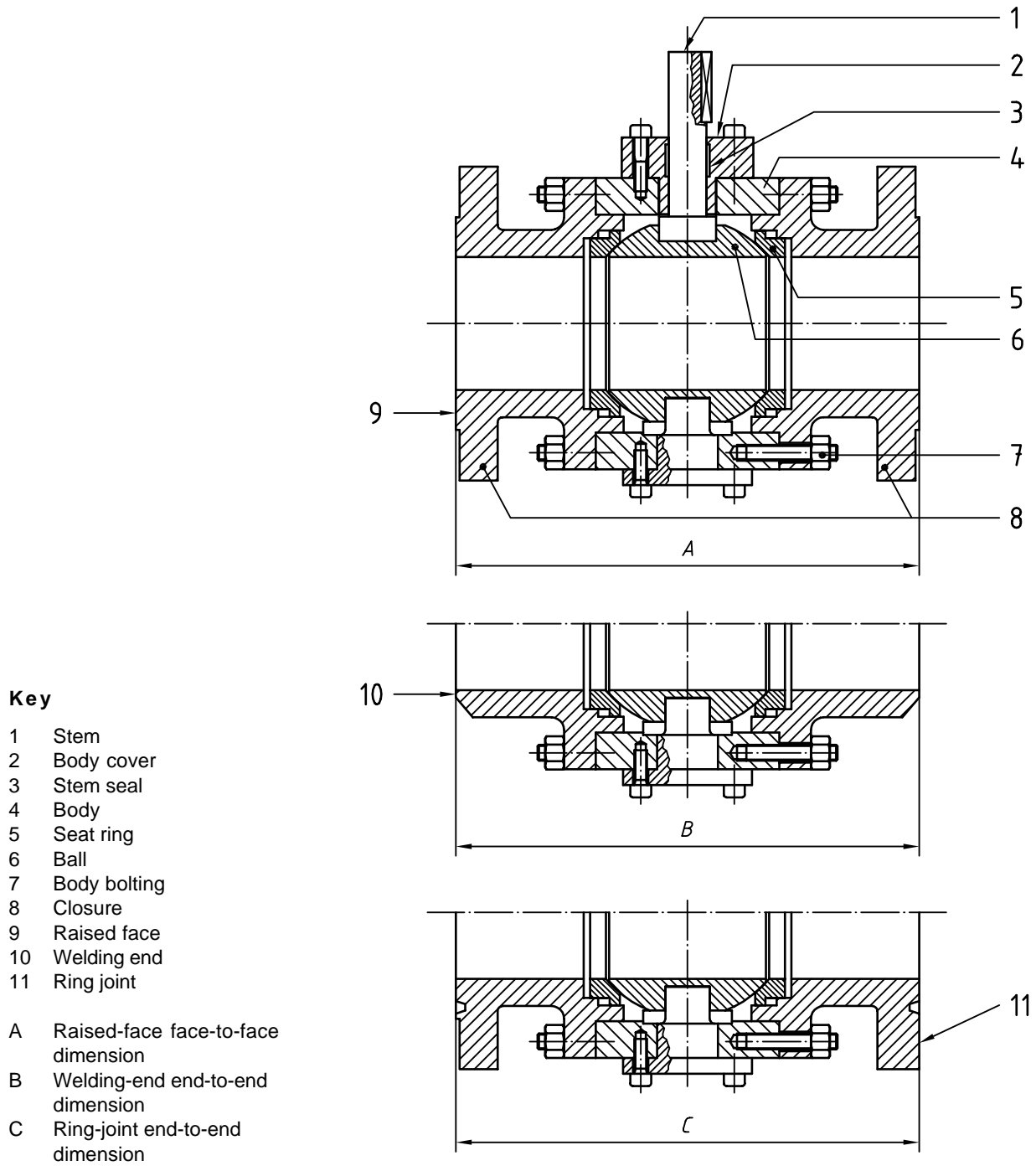

Figure 5—Three-piece ball valve

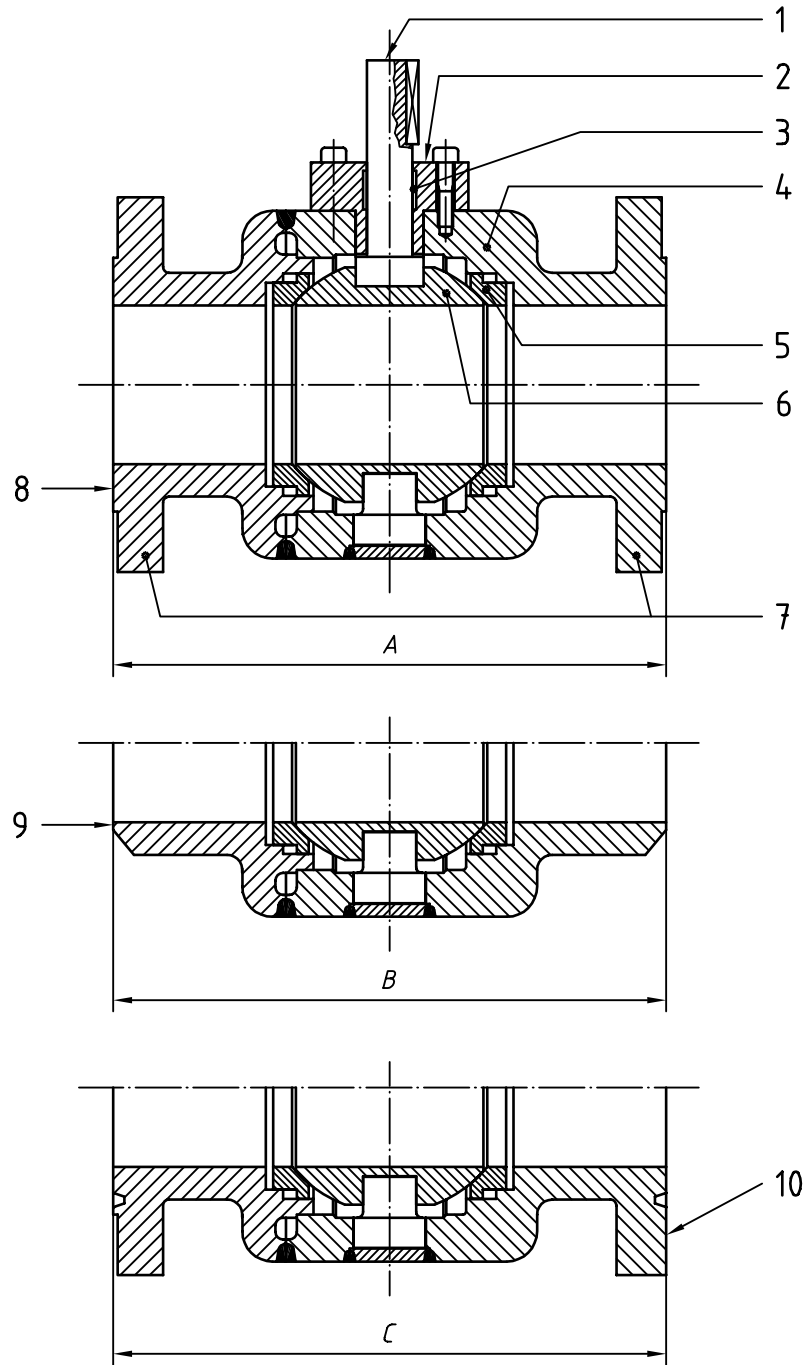
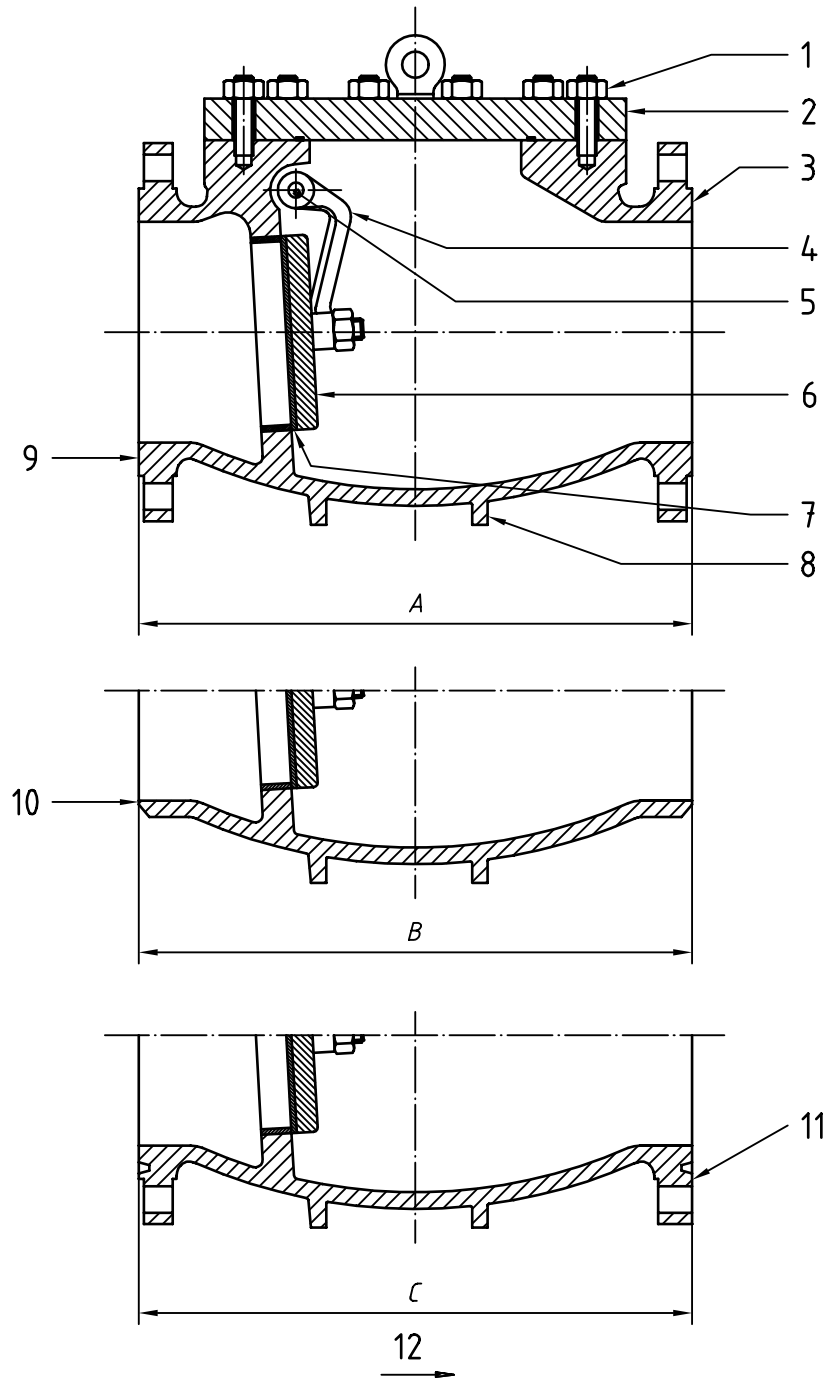

Figure 6—Welded-body ball valve



**Key**

- 1 Cover bolting
  - 2 Cover
  - 3 Body
  - 4 Clapper disc arm
  - 5 Shaft
  - 6 Clapper disc
  - 7 Seat ring
  - 8 Support ribs or legs
  - 9 Raised face
  - 10 Welding end
  - 11 Ring joint
  - 12 Direction of flow
- 
- A Raised-face face-to-face dimension
  - B Welding-end end-to-end dimension
  - C Ring-joint end-to-end dimension

**Figure 7—Reduced-opening swing check valve**

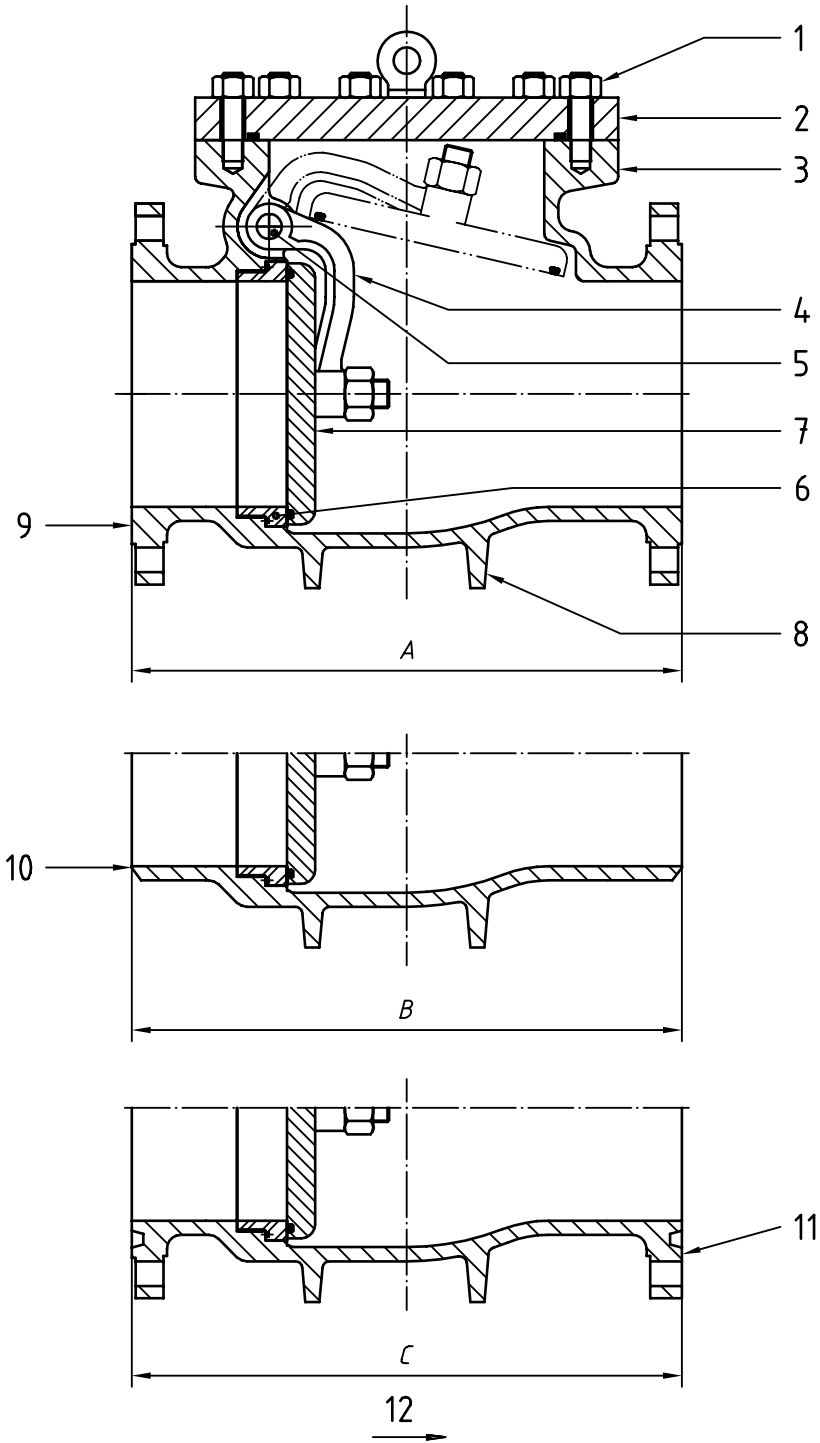

**Key**

- 1 Cover bolting
  - 2 Cover
  - 3 Body
  - 4 Clapper disc arm
  - 5 Shaft
  - 6 Seat ring
  - 7 Clapper disc
  - 8 Support ribs or legs
  - 9 Raised face
  - 10 Welding end
  - 11 Ring joint
  - 12 Direction of flow
- 
- A Raised-face face-to-face dimension
  - B Welding-end end-to-end dimension
  - C Ring-joint end-to-end dimension

**Figure 8—Full-opening swing check valve**



**Key**

- 1 Body
- 2 Hinge
- 3 Nut
- 4 Closure plate/stud assembly
- 5 Seat ring
- 6 Bearing spacers
- 7 Hinge pin
- 8 Hinge pin retainers
- 9 Direction of flow

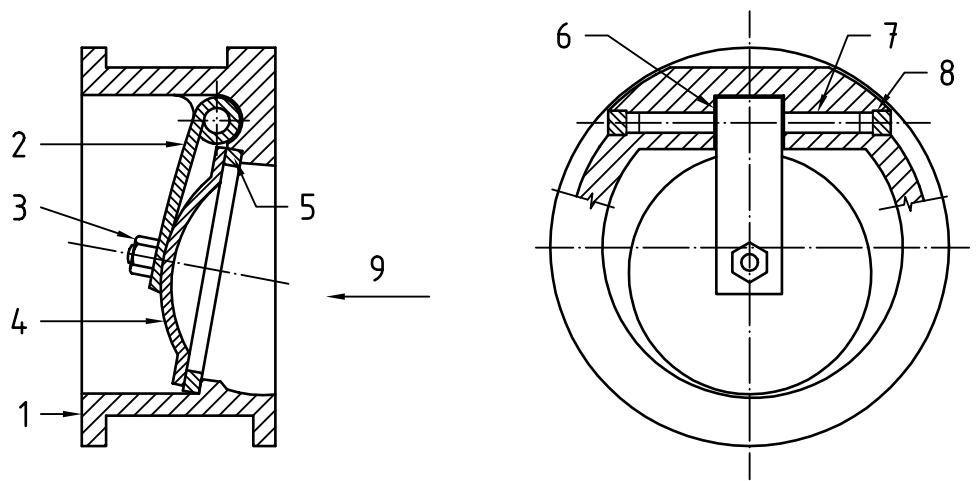

**Figure 9—Single-plate wafer-type check valve, long pattern**

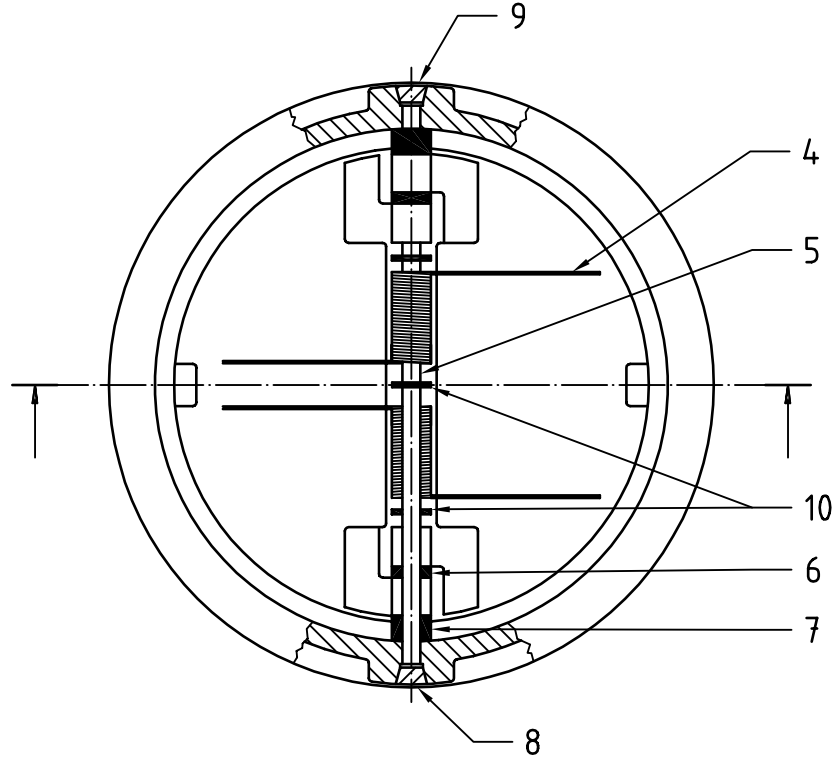
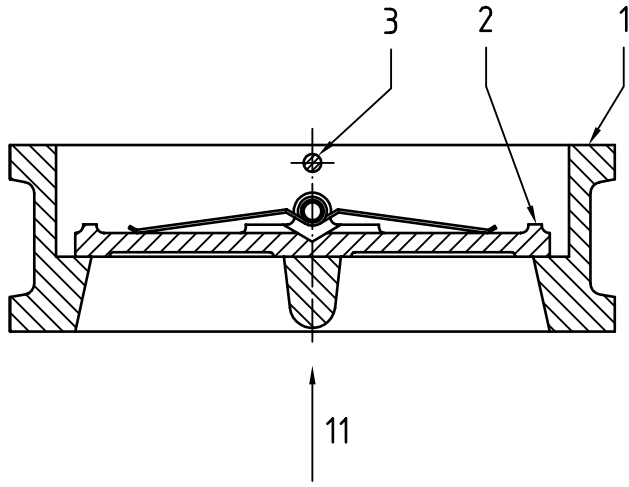

**Key**

- 1 Body
- 2 Closure plate
- 3 Stop pin
- 4 Spring
- 5 Hinge pin
- 6 Plate lug bearings
- 7 Body lug bearings
- 8 Stop pin retainers
- 9 Hinge pin retainers
- 10 Spring bearings
- 11 Direction of flow

**Figure 10—Typical dual-plate wafer-type check valve, long pattern**

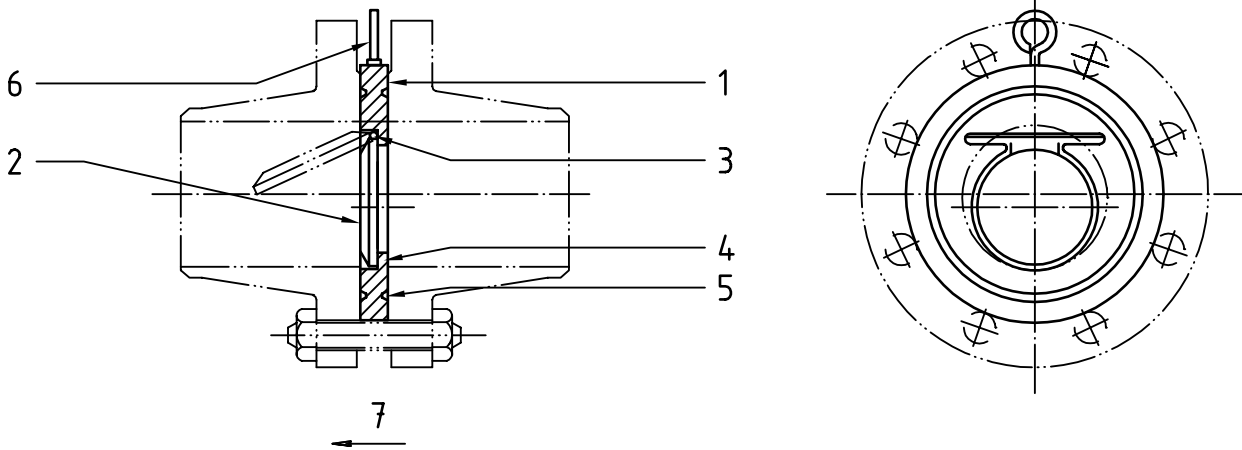

**Key**

- |   |              |   |                   |
|---|--------------|---|-------------------|
| 1 | Body         | 5 | Body seal         |
| 2 | Clapper      | 6 | Lifting eye       |
| 3 | Pin          | 7 | Direction of flow |
| 4 | Clapper seal |   |                   |

**Figure 11—Single-plate wafer-type check valve, short pattern**

**6 Design**

**6.1 Pressure and temperature rating**

The nominal pressure (PN) class or the ANSI rating class shall be used for the specification of the required pressure class.

Valves covered by this International Standard should be furnished in one of the following classes:

- |                    |                     |
|--------------------|---------------------|
| PN 20 (Class 150)  | PN 150 (Class 900)  |
| PN 50 (Class 300)  | PN 250 (Class 1500) |
| PN 64 (Class 400)  | PN 420 (Class 2500) |
| PN 100 (Class 600) |                     |

Pressure classes shall be specified by the purchaser in accordance with the applicable rating tables for material groups in ASME B16.34.

The purchaser may specify intermediate design pressures and temperatures for his specific application.

Allowable operating pressures and temperatures for valves made of materials not covered by ASME B16.34 shall be determined by calculations in accordance with an agreed pressure vessel design standard, such as ASME Section VIII, Division 1 and Division 2, or BS 5500.

Non-metallic parts may limit minimum and maximum operating pressures and temperatures.

The maximum operating pressure at the minimum and maximum operating temperatures shall be marked on the nameplate.

## 6.2 Sizes

All valves, except for reduced-opening valves, shall be furnished in the nominal sizes (DN) listed in Tables 2 to 6. Reduced-opening valves shall be furnished in the nominal sizes in accordance with Table 1.

NOTE In this International Standard, DN sizes are stated first followed by the equivalent NPS size between brackets.

Except for reduced-opening valves, valve sizes shall be specified by the nominal sizes (DN) or nominal pipe size (NPS).

Reduced-opening valves with a circular opening through the obturator shall be specified by the nominal size of the end connections and the nominal size of the minimum bore of the obturator in accordance with Table 1, except that for valve sizes DN 50 (NPS 2) or smaller the actual bore of the obturator shall be specified. For example, a DN 400 valve with a reduced 334-mm-diameter circular opening through the obturator shall be specified as 400 × 350.

Reduced-opening valves with a non-circular opening through the obturator and reduced-opening check valves shall be designated as reduced-bore valves and specified by the nominal size corresponding to the end connections followed by the letter "R". For example, a reduced-bore valve with DN 400 end connections and a 381 × 305 mm rectangular opening through the obturator shall be specified as 400R.

## 6.3 Face-to-face and end-to-end dimensions

Unless otherwise agreed, face-to-face and end-to-end dimensions of valves shall be in accordance with Tables 2 to 6.

Face-to-face and end-to-end dimensions for valve sizes not specified in Tables 2 to 6 shall be in accordance with ASME B16.10. Face-to-face and end-to-end dimensions not shown in Tables 2 to 6 or in ASME B16.10 shall be established by agreement.

The length of valves having one welding end and one flanged end shall be determined by adding half the length of a flanged-end valve to half the length of a welding-end valve.

Tolerances on the face-to-face and end-to-end dimensions shall be  $\pm 2$  mm for valve sizes DN 250 and smaller, and  $\pm 3$  mm for valve sizes DN 300 and larger.

The nominal size and face-to-face or end-to-end dimensions shall be stated on the nameplate if not specified in or not in accordance with Tables 2 to 6.

**Table 2—Gate valves—Face-to-face (A) and end-to-end (B and C) dimensions (mm)**

| DN<br>(mm) | NPS<br>(inches) | Raised<br>face<br>A      | Welding<br>end<br>B | Ring<br>joint<br>C | Raised<br>face<br>A       | Welding<br>end<br>B | Ring<br>joint<br>C |
|------------|-----------------|--------------------------|---------------------|--------------------|---------------------------|---------------------|--------------------|
|            |                 | <b>PN 20 (Class 150)</b> |                     |                    | <b>PN 50 (Class 300)</b>  |                     |                    |
| 50         | 2               | 178                      | 216                 | 191                | 216                       | 216                 | 232                |
| 65         | 2½              | 191                      | 241                 | 203                | 241                       | 241                 | 257                |
| 80         | 3               | 203                      | 283                 | 216                | 283                       | 283                 | 298                |
| 100        | 4               | 229                      | 305                 | 241                | 305                       | 305                 | 321                |
| 150        | 6               | 267                      | 403                 | 279                | 403                       | 403                 | 419                |
| 200        | 8               | 292                      | 419                 | 305                | 419                       | 419                 | 435                |
| 250        | 10              | 330                      | 457                 | 343                | 457                       | 457                 | 473                |
| 300        | 12              | 356                      | 502                 | 368                | 502                       | 502                 | 518                |
| 350        | 14              | 381                      | 572                 | 394                | 762                       | 762                 | 778                |
| 400        | 16              | 406                      | 610                 | 419                | 838                       | 838                 | 854                |
| 450        | 18              | 432                      | 660                 | 445                | 914                       | 914                 | 930                |
| 500        | 20              | 457                      | 711                 | 470                | 991                       | 991                 | 1010               |
| 550        | 22              | —                        | —                   | —                  | 1092                      | 1092                | 1114               |
| 600        | 24              | 508                      | 813                 | 521                | 1143                      | 1143                | 1165               |
| 650        | 26              | 559                      | 864                 | —                  | 1245                      | 1245                | 1270               |
| 700        | 28              | 610                      | 914                 | —                  | 1346                      | 1346                | 1372               |
| 750        | 30              | 610 <sup>a</sup>         | 914                 | —                  | 1397                      | 1397                | 1422               |
| 800        | 32              | 711                      | 965                 | —                  | 1524                      | 1524                | 1553               |
| 850        | 34              | 762                      | 1016                | —                  | 1626                      | 1626                | 1654               |
| 900        | 36              | 711 <sup>b</sup>         | 1016                | —                  | 1727                      | 1727                | 1756               |
|            |                 | <b>PN 64 (Class 400)</b> |                     |                    | <b>PN 100 (Class 600)</b> |                     |                    |
| 50         | 2               | 292                      | 292                 | 295                | 292                       | 292                 | 295                |
| 65         | 2½              | 330                      | 330                 | 333                | 330                       | 330                 | 333                |
| 80         | 3               | 356                      | 356                 | 359                | 356                       | 356                 | 359                |
| 100        | 4               | 406                      | 406                 | 410                | 432                       | 432                 | 435                |
| 150        | 6               | 495                      | 495                 | 498                | 559                       | 559                 | 562                |
| 200        | 8               | 597                      | 597                 | 600                | 660                       | 660                 | 664                |
| 250        | 10              | 673                      | 673                 | 676                | 787                       | 787                 | 791                |
| 300        | 12              | 762                      | 762                 | 765                | 838                       | 838                 | 841                |
| 350        | 14              | 826                      | 826                 | 829                | 889                       | 889                 | 892                |
| 400        | 16              | 902                      | 902                 | 905                | 991                       | 991                 | 994                |
| 450        | 18              | 978                      | 978                 | 981                | 1092                      | 1092                | 1095               |
| 500        | 20              | 1054                     | 1054                | 1060               | 1194                      | 1194                | 1200               |
| 550        | 22              | 1143                     | 1143                | 1153               | 1295                      | 1295                | 1305               |
| 600        | 24              | 1232                     | 1232                | 1241               | 1397                      | 1397                | 1407               |
| 650        | 26              | 1308                     | 1308                | 1321               | 1448                      | 1448                | 1461               |
| 700        | 28              | 1397                     | 1397                | 1410               | 1549                      | 1549                | 1562               |
| 750        | 30              | 1524                     | 1524                | 1537               | 1651                      | 1651                | 1664               |
| 800        | 32              | 1651                     | 1651                | 1667               | 1778                      | 1778                | 1794               |
| 850        | 34              | 1778                     | 1778                | 1794               | 1930                      | 1930                | 1946               |
| 900        | 36              | 1880                     | 1880                | 1895               | 2083                      | 2083                | 2099               |

Table 2 (concluded)

| DN<br>(mm)  | NPS<br>(inches) | Raised<br>face             | Welding<br>end | Ring<br>joint | Raised<br>face             | Welding<br>end | Ring<br>joint |
|---|-----------------|----------------------------|----------------|---------------|----------------------------|----------------|---------------|
|   |                 | A                          | B              | C             | A                          | B              | C             |
|   |                 | <b>PN 150 (Class 900)</b>  |                |               | <b>PN 250 (Class 1500)</b> |                |               |
| 50  | 2               | 368                        | 368            | 371           | 368                        | 368            | 371           |
| 65  | 2½              | 419                        | 419            | 422           | 419                        | 419            | 422           |
| 80  | 3               | 381                        | 381            | 384           | 470                        | 470            | 473           |
| 100   | 4               | 457                        | 457            | 460           | 546                        | 546            | 549           |
| 150   | 6               | 610                        | 610            | 613           | 705                        | 705            | 711           |
| 200   | 8               | 737                        | 737            | 740           | 832                        | 832            | 841           |
| 250   | 10              | 838                        | 838            | 841           | 991                        | 991            | 1000          |
| 300   | 12              | 965                        | 965            | 968           | 1130                       | 1130           | 1146          |
| 350   | 14              | 1029                       | 1029           | 1038          | 1257                       | 1257           | 1276          |
| 400   | 16              | 1130                       | 1130           | 1140          | 1384                       | 1384           | 1407          |
| 450   | 18              | 1219                       | 1219           | 1232          | 1537                       | 1537           | 1559          |
| 500   | 20              | 1321                       | 1321           | 1334          | 1664                       | 1664           | 1686          |
| 550   | 22              | —                          | —              | —             | —                          | —              | —             |
| 600   | 24              | 1549                       | 1549           | 1568          | 1943                       | 1943           | 1972          |
|   |                 | <b>PN 420 (Class 2500)</b> |                |               |                            |                |               |
| 50  | 2               | 451                        | 451            | 454           |                            |                |               |
| 65  | 2½              | 508                        | 508            | 514           |                            |                |               |
| 80  | 3               | 578                        | 578            | 584           |                            |                |               |
| 100   | 4               | 673                        | 673            | 683           |                            |                |               |
| 150   | 6               | 914                        | 914            | 927           |                            |                |               |
| 200   | 8               | 1022                       | 1022           | 1038          |                            |                |               |
| 250   | 10              | 1270                       | 1270           | 1292          |                            |                |               |
| 300   | 12              | 1422                       | 1422           | 1445          |                            |                |               |
| <p><sup>a</sup> Through-conduit valves shall be 650 mm.</p> <p><sup>b</sup> Through-conduit valves shall be 800 mm.</p> |                 |                            |                |               |                            |                |               |

**Table 3 — Plug valves — Face-to-face (A) and end-to-end (B and C) dimensions (mm)**

| DN<br>(mm)               | NPS<br>(inches) | Short-pattern       |                     |                    | Reduced             |                     |                    | Venturi             |                     |                    | Round-port, full-bore |                     |                    |
|--------------------------|-----------------|---------------------|---------------------|--------------------|---------------------|---------------------|--------------------|---------------------|---------------------|--------------------|-----------------------|---------------------|--------------------|
|                          |                 | Raised<br>face<br>A | Welding<br>end<br>B | Ring<br>joint<br>C | Raised<br>face<br>A | Welding<br>end<br>B | Ring<br>joint<br>C | Raised<br>face<br>A | Welding<br>end<br>B | Ring<br>joint<br>C | Raised<br>face<br>A   | Welding<br>End<br>B | Ring<br>joint<br>C |
| <b>PN 20 (Class 150)</b> |                 |                     |                     |                    |                     |                     |                    |                     |                     |                    |                       |                     |                    |
| 50                       | 2               | 178                 | 267                 | 191                | —                   | —                   | —                  | —                   | —                   | —                  | 267                   | —                   | 279                |
| 65                       | 2½              | 191                 | 305                 | 203                | —                   | —                   | —                  | —                   | —                   | —                  | 298                   | —                   | 311                |
| 80                       | 3               | 203                 | 330                 | 216                | —                   | —                   | —                  | —                   | —                   | —                  | 343                   | —                   | 356                |
| 100                      | 4               | 229                 | 356                 | 241                | —                   | —                   | —                  | —                   | —                   | —                  | 432                   | —                   | 445                |
| 150                      | 6               | 267                 | 457                 | 279                | 394                 | —                   | 406                | —                   | —                   | —                  | 546                   | —                   | 559                |
| 200                      | 8               | 292                 | 521                 | 305                | 457                 | —                   | 470                | —                   | —                   | —                  | 622                   | —                   | 635                |
| 250                      | 10              | 330                 | 559                 | 343                | 533                 | —                   | 546                | 533                 | 559                 | 546                | 660                   | —                   | 673                |
| 300                      | 12              | 356                 | 635                 | 368                | 610                 | —                   | 622                | 610                 | 635                 | 622                | 762                   | —                   | 775                |
| 350                      | 14              | —                   | —                   | —                  | —                   | —                   | —                  | 686                 | 686                 | 699                | —                     | —                   | —                  |
| 400                      | 16              | —                   | —                   | —                  | —                   | —                   | —                  | 762                 | 762                 | 775                | —                     | —                   | —                  |
| 450                      | 18              | —                   | —                   | —                  | —                   | —                   | —                  | 864                 | 864                 | 876                | —                     | —                   | —                  |
| 500                      | 20              | —                   | —                   | —                  | —                   | —                   | —                  | 914                 | 914                 | 927                | —                     | —                   | —                  |
| 600                      | 24              | —                   | —                   | —                  | —                   | —                   | —                  | 1067                | 1067                | 1080               | —                     | —                   | —                  |
| <b>PN 50 (Class 300)</b> |                 |                     |                     |                    |                     |                     |                    |                     |                     |                    |                       |                     |                    |
| 50                       | 2               | 216                 | 267                 | 232                | —                   | —                   | —                  | —                   | —                   | —                  | 283                   | 283                 | 298                |
| 65                       | 2½              | 241                 | 305                 | 257                | —                   | —                   | —                  | —                   | —                   | —                  | 330                   | 330                 | 346                |
| 80                       | 3               | 283                 | 330                 | 298                | —                   | —                   | —                  | —                   | —                   | —                  | 387                   | 387                 | 403                |
| 100                      | 4               | 305                 | 356                 | 321                | —                   | —                   | —                  | —                   | —                   | —                  | 457                   | 457                 | 473                |
| 150                      | 6               | 403                 | 457                 | 419                | 403                 | —                   | 419                | 403                 | 457                 | 419                | 559                   | 559                 | 575                |
| 200                      | 8               | 419                 | 521                 | 435                | 502                 | —                   | 518                | 419                 | 521                 | 435                | 686                   | 686                 | 702                |
| 250                      | 10              | 457                 | 559                 | 473                | 568                 | —                   | 584                | 457                 | 559                 | 473                | 826                   | 826                 | 841                |
| 300                      | 12              | 502                 | 635                 | 518                | —                   | —                   | —                  | 502                 | 635                 | 518                | 965                   | 965                 | 981                |
| 350                      | 14              | —                   | —                   | —                  | —                   | —                   | —                  | 762                 | 762                 | 778                | —                     | —                   | —                  |
| 400                      | 16              | —                   | —                   | —                  | —                   | —                   | —                  | 838                 | 838                 | 854                | —                     | —                   | —                  |
| 450                      | 18              | —                   | —                   | —                  | 914                 | —                   | 930                | 914                 | 914                 | 930                | —                     | —                   | —                  |
| 500                      | 20              | —                   | —                   | —                  | 991                 | —                   | 1010               | 991                 | 991                 | 1010               | —                     | —                   | —                  |
| 550                      | 22              | —                   | —                   | —                  | 1092                | —                   | 1114               | 1092                | 1092                | 1114               | —                     | —                   | —                  |
| 600                      | 24              | —                   | —                   | —                  | 1143                | —                   | 1165               | 1143                | 1143                | 1165               | —                     | —                   | —                  |
| 650                      | 26              | —                   | —                   | —                  | 1245                | —                   | 1270               | 1245                | 1245                | 1270               | —                     | —                   | —                  |
| 700                      | 28              | —                   | —                   | —                  | 1346                | —                   | 1372               | 1346                | 1346                | 1372               | —                     | —                   | —                  |
| 750                      | 30              | —                   | —                   | —                  | 1397                | —                   | 1422               | 1397                | 1397                | 1422               | —                     | —                   | —                  |
| 800                      | 32              | —                   | —                   | —                  | 1524                | —                   | 1553               | 1524                | 1524                | 1553               | —                     | —                   | —                  |
| 850                      | 34              | —                   | —                   | —                  | 1626                | —                   | 1654               | 1626                | 1626                | 1654               | —                     | —                   | —                  |
| 900                      | 36              | —                   | —                   | —                  | 1727                | —                   | 1756               | 1727                | 1727                | 1756               | —                     | —                   | —                  |

Table 3 (continued)

| DN<br>(mm)               | NPS<br>(inches) | Short-pattern       |                     |                    | Reduced             |                     |                    | Venturi             |                     |                    | Round-port, full-bore |                     |                    |
|--------------------------|-----------------|---------------------|---------------------|--------------------|---------------------|---------------------|--------------------|---------------------|---------------------|--------------------|-----------------------|---------------------|--------------------|
|                          |                 | Raised<br>face<br>A | Welding<br>end<br>B | Ring<br>joint<br>C | Raised<br>face<br>A | Welding<br>end<br>B | Ring<br>joint<br>C | Raised<br>face<br>A | Welding<br>end<br>B | Ring<br>joint<br>C | Raised<br>face<br>A   | Welding<br>End<br>B | Ring<br>joint<br>C |
| <b>PN 64 (Class 400)</b> |                 |                     |                     |                    |                     |                     |                    |                     |                     |                    |                       |                     |                    |
| 50                       | 2               | —                   | —                   | —                  | 292                 | 292                 | 295                | —                   | —                   | —                  | 330                   | —                   | 333                |
| 65                       | 2½              | —                   | —                   | —                  | 330                 | 330                 | 333                | —                   | —                   | —                  | 381                   | —                   | 384                |
| 80                       | 3               | —                   | —                   | —                  | 356                 | 356                 | 359                | —                   | —                   | —                  | 445                   | —                   | 448                |
| 100                      | 4               | —                   | —                   | —                  | 406                 | 406                 | 410                | —                   | —                   | —                  | 483                   | 559                 | 486                |
| 150                      | 6               | —                   | —                   | —                  | 495                 | 495                 | 498                | 495                 | 495                 | 498                | 610                   | 711                 | 613                |
| 200                      | 8               | —                   | —                   | —                  | 597                 | 597                 | 600                | 597                 | 597                 | 600                | 737                   | 845                 | 740                |
| 250                      | 10              | —                   | —                   | —                  | 673                 | 673                 | 676                | 673                 | 673                 | 676                | 889                   | 889                 | 892                |
| 300                      | 12              | —                   | —                   | —                  | 762                 | 762                 | 765                | 762                 | 762                 | 765                | 1016                  | 1016                | 1019               |
| 350                      | 14              | —                   | —                   | —                  | —                   | —                   | —                  | 826                 | 826                 | 829                | —                     | —                   | —                  |
| 400                      | 16              | —                   | —                   | —                  | —                   | —                   | —                  | 902                 | 902                 | 905                | —                     | —                   | —                  |
| 450                      | 18              | —                   | —                   | —                  | —                   | —                   | —                  | 978                 | 978                 | 981                | —                     | —                   | —                  |
| 500                      | 20              | —                   | —                   | —                  | —                   | —                   | —                  | 1054                | 1054                | 1060               | —                     | —                   | —                  |
| 550                      | 22              | —                   | —                   | —                  | —                   | —                   | —                  | 1143                | 1143                | 1153               | —                     | —                   | —                  |
| 600                      | 24              | —                   | —                   | —                  | —                   | —                   | —                  | 1232                | 1232                | 1241               | —                     | —                   | —                  |
| 650                      | 26              | —                   | —                   | —                  | —                   | —                   | —                  | 1308                | 1308                | 1321               | —                     | —                   | —                  |
| 700                      | 28              | —                   | —                   | —                  | —                   | —                   | —                  | 1397                | 1397                | 1410               | —                     | —                   | —                  |
| 750                      | 30              | —                   | —                   | —                  | —                   | —                   | —                  | 1524                | 1524                | 1537               | —                     | —                   | —                  |
| 800                      | 32              | —                   | —                   | —                  | —                   | —                   | —                  | 1651                | 1651                | 1667               | —                     | —                   | —                  |
| 850                      | 34              | —                   | —                   | —                  | —                   | —                   | —                  | 1778                | 1778                | 1794               | —                     | —                   | —                  |
| 900                      | 36              | —                   | —                   | —                  | —                   | —                   | —                  | 1880                | 1880                | 1895               | —                     | —                   | —                  |



Table 3 (continued)

| DN<br>(mm)                 | NPS<br>(inches)               | Reduced             |                     |                    | Venturi             |                     |                    | Round-port, full-bore |                     |                    |
|----------------------------|-------------------------------|---------------------|---------------------|--------------------|---------------------|---------------------|--------------------|-----------------------|---------------------|--------------------|
|                            |                               | Raised<br>face<br>A | Welding<br>end<br>B | Ring<br>joint<br>C | Raised<br>face<br>A | Welding<br>end<br>B | Ring<br>joint<br>C | Raised<br>face<br>A   | Welding<br>End<br>B | Ring<br>joint<br>C |
| <b>PN 100 (Class 600)</b>  |                               |                     |                     |                    |                     |                     |                    |                       |                     |                    |
| 50                         | 2                             | 292                 | 292                 | 295                | —                   | —                   | —                  | 330                   | —                   | 333                |
| 65                         | 2 <sup>1</sup> / <sub>2</sub> | 330                 | 330                 | 333                | —                   | —                   | —                  | 381                   | —                   | 384                |
| 80                         | 3                             | 356                 | 356                 | 359                | —                   | —                   | —                  | 445                   | —                   | 448                |
| 100                        | 4                             | 432                 | 432                 | 435                | —                   | —                   | —                  | 508                   | 559                 | 511                |
| 150                        | 6                             | 559                 | 559                 | 562                | 559                 | 559                 | 562                | 660                   | 711                 | 664                |
| 200                        | 8                             | 660                 | 660                 | 664                | 660                 | 660                 | 664                | 794                   | 845                 | 797                |
| 250                        | 10                            | 787                 | 787                 | 791                | 787                 | 787                 | 791                | 940                   | 1016                | 943                |
| 300                        | 12                            | —                   | —                   | —                  | 838                 | 838                 | 841                | 1067                  | 1067                | 1070               |
| 350                        | 14                            | —                   | —                   | —                  | 889                 | 889                 | 892                | —                     | —                   | —                  |
| 400                        | 16                            | —                   | —                   | —                  | 991                 | 991                 | 994                | —                     | —                   | —                  |
| 450                        | 18                            | —                   | —                   | —                  | 1092                | 1092                | 1095               | —                     | —                   | —                  |
| 500                        | 20                            | —                   | —                   | —                  | 1194                | 1194                | 1200               | —                     | —                   | —                  |
| 550                        | 22                            | —                   | —                   | —                  | 1295                | 1295                | 1305               | —                     | —                   | —                  |
| 600                        | 24                            | —                   | —                   | —                  | 1397                | 1397                | 1407               | —                     | —                   | —                  |
| 650                        | 26                            | —                   | —                   | —                  | 1448                | 1448                | 1461               | —                     | —                   | —                  |
| 750                        | 30                            | —                   | —                   | —                  | 1651                | 1651                | 1664               | —                     | —                   | —                  |
| 800                        | 32                            | —                   | —                   | —                  | 1778                | 1778                | 1794               | —                     | —                   | —                  |
| 850                        | 34                            | —                   | —                   | —                  | 1930                | 1930                | 1946               | —                     | —                   | —                  |
| 900                        | 36                            | —                   | —                   | —                  | 2083                | 2083                | 2099               | —                     | —                   | —                  |
| <b>PN 150 (Class 900)</b>  |                               |                     |                     |                    |                     |                     |                    |                       |                     |                    |
| 50                         | 2                             | 368                 | —                   | 371                | —                   | —                   | —                  | 381                   | —                   | 384                |
| 65                         | 2 <sup>1</sup> / <sub>2</sub> | 419                 | —                   | 422                | —                   | —                   | —                  | 432                   | —                   | 435                |
| 80                         | 3                             | 381                 | 381                 | 384                | —                   | —                   | —                  | 470                   | —                   | 473                |
| 100                        | 4                             | 457                 | 457                 | 460                | —                   | —                   | —                  | 559                   | —                   | 562                |
| 150                        | 6                             | 610                 | 610                 | 613                | 610                 | 610                 | 613                | 737                   | —                   | 740                |
| 200                        | 8                             | 737                 | 737                 | 740                | 737                 | 737                 | 740                | 813                   | —                   | 816                |
| 250                        | 10                            | 838                 | 838                 | 841                | 838                 | 838                 | 841                | 965                   | —                   | 968                |
| 300                        | 12                            | —                   | —                   | —                  | 965                 | 965                 | 968                | 1118                  | —                   | 1121               |
| 400                        | 16                            | —                   | —                   | —                  | 1130                | 1130                | 1140               | —                     | —                   | —                  |
| <b>PN 250 (Class 1500)</b> |                               |                     |                     |                    |                     |                     |                    |                       |                     |                    |
| 50                         | 2                             | 368                 | —                   | 371                | —                   | —                   | —                  | 391                   | —                   | 394                |
| 65                         | 2 <sup>1</sup> / <sub>2</sub> | 419                 | —                   | 422                | —                   | —                   | —                  | 454                   | —                   | 457                |
| 80                         | 3                             | 470                 | 470                 | 473                | —                   | —                   | —                  | 524                   | —                   | 527                |
| 100                        | 4                             | 546                 | 546                 | 549                | —                   | —                   | —                  | 625                   | —                   | 629                |
| 150                        | 6                             | 705                 | 705                 | 711                | 705                 | 705                 | 711                | 787                   | —                   | 794                |
| 200                        | 8                             | 832                 | 832                 | 841                | 832                 | 832                 | 841                | 889                   | —                   | 899                |
| 250                        | 10                            | 991                 | 991                 | 1000               | 991                 | 991                 | 1000               | 1067                  | —                   | 1076               |
| 300                        | 12                            | 1130                | 1130                | 1146               | 1130                | 1130                | 1146               | 1219                  | —                   | 1235               |

Table 3 (concluded)

| DN<br>(mm)                 | NPS<br>(inches)               | Reduced             |                     |                    | Venturi             |                     |                    | Round-port, full-bore |                     |                    |
|----------------------------|-------------------------------|---------------------|---------------------|--------------------|---------------------|---------------------|--------------------|-----------------------|---------------------|--------------------|
|                            |                               | Raised<br>face<br>A | Welding<br>end<br>B | Ring<br>joint<br>C | Raised<br>face<br>A | Welding<br>end<br>B | Ring<br>joint<br>C | Raised<br>face<br>A   | Welding<br>End<br>B | Ring<br>joint<br>C |
| <b>PN 420 (Class 2500)</b> |                               |                     |                     |                    |                     |                     |                    |                       |                     |                    |
| 50                         | 2                             | 451                 | —                   | 454                | —                   | —                   | —                  | —                     | —                   | —                  |
| 65                         | 2 <sup>1</sup> / <sub>2</sub> | 508                 | —                   | 514                | —                   | —                   | —                  | —                     | —                   | —                  |
| 80                         | 3                             | 578                 | —                   | 584                | —                   | —                   | —                  | —                     | —                   | —                  |
| 100                        | 4                             | 673                 | —                   | 683                | —                   | —                   | —                  | —                     | —                   | —                  |
| 150                        | 6                             | 914                 | —                   | 927                | —                   | —                   | —                  | —                     | —                   | —                  |
| 200                        | 8                             | 1022                | —                   | 1038               | —                   | —                   | —                  | —                     | —                   | —                  |
| 250                        | 10                            | 1270                | —                   | 1292               | —                   | —                   | —                  | —                     | —                   | —                  |
| 300                        | 12                            | 1422                | —                   | 1445               | —                   | —                   | —                  | —                     | —                   | —                  |

**Table 4—Ball valves—Face-to-face (A) and end-to-end (B and C) dimensions (mm)**

|                          |                               | Full-bore and reduced-bore |                     |                    | Short-pattern, full-bore and reduced-bore |                     |                    |
|--------------------------|-------------------------------|----------------------------|---------------------|--------------------|---|---------------------|--------------------|
| DN<br>(mm)               | NPS<br>(inches)               | Raised<br>face<br>A        | Welding<br>end<br>B | Ring<br>joint<br>C | Raised<br>face<br>A                       | Welding<br>End<br>B | Ring<br>joint<br>C |
| <b>PN 20 (Class 150)</b> |                               |                            |                     |                    |   |                     |                    |
| 50                       | 2                             | 178                        | 216                 | 191                | —   | —                   | —                  |
| 65                       | 2 <sup>1</sup> / <sub>2</sub> | 191                        | 241                 | 203                | —   | —                   | —                  |
| 80                       | 3                             | 203                        | 283                 | 216                | —   | —                   | —                  |
| 100                      | 4                             | 229                        | 305                 | 241                | —   | —                   | —                  |
| 150                      | 6                             | 394                        | 457                 | 406                | 267                                       | 403                 | 279                |
| 200                      | 8                             | 457                        | 521                 | 470                | 292                                       | 419                 | 305                |
| 250                      | 10                            | 533                        | 559                 | 546                | 330                                       | 457                 | 343                |
| 300                      | 12                            | 610                        | 635                 | 622                | 356                                       | 502                 | 368                |
| 350                      | 14                            | 686                        | 762                 | 699                | —   | —                   | —                  |
| 400                      | 16                            | 762                        | 838                 | 775                | —   | —                   | —                  |
| 450                      | 18                            | 864                        | 914                 | 876                | —   | —                   | —                  |
| 500                      | 20                            | 914                        | 991                 | 927                | —   | —                   | —                  |
| 550                      | 22                            | —                          | —                   | —                  | —   | —                   | —                  |
| 600                      | 24                            | 1 067                      | 1 143               | 1 080              | —   | —                   | —                  |
| 650                      | 26                            | 1 143                      | 1 245               | —                  | —   | —                   | —                  |
| 700                      | 28                            | 1 245                      | 1 346               | —                  | —   | —                   | —                  |
| 750                      | 30                            | 1 295                      | 1 397               | —                  | —   | —                   | —                  |
| 800                      | 32                            | 1 372                      | 1 524               | —                  | —   | —                   | —                  |
| 850                      | 34                            | 1 473                      | 1 626               | —                  | —   | —                   | —                  |
| 900                      | 36                            | 1 524                      | 1 727               | —                  | —   | —                   | —                  |
| 950                      | 38                            | —                          | —                   | —                  | —   | —                   | —                  |
| 1 000                    | 40                            | —                          | —                   | —                  | —   | —                   | —                  |
| 1 100                    | 42                            | —                          | —                   | —                  | —   | —                   | —                  |
| 1 200                    | 48                            | —                          | —                   | —                  | —   | —                   | —                  |
| 1 400                    | 54                            | —                          | —                   | —                  | —   | —                   | —                  |
| 1 500                    | 60                            | —                          | —                   | —                  | —   | —                   | —                  |

Table 4 (continued)

|                          |                 | Full-bore and reduced-bore |                     |                    | Short-pattern, full-bore and reduced-bore |                     |                    |
|--------------------------|-----------------|----------------------------|---------------------|--------------------|---|---------------------|--------------------|
| DN<br>(mm)               | NPS<br>(inches) | Raised<br>face<br>A        | Welding<br>end<br>B | Ring<br>joint<br>C | Raised<br>face<br>A                       | Welding<br>End<br>B | Ring<br>joint<br>C |
| <b>PN 50 (Class 300)</b> |                 |                            |                     |                    |   |                     |                    |
| 50                       | 2               | 216                        | 216                 | 232                | —   | —                   | —                  |
| 65                       | 2½              | 241                        | 241                 | 257                | —   | —                   | —                  |
| 80                       | 3               | 283                        | 283                 | 298                | —   | —                   | —                  |
| 100                      | 4               | 305                        | 305                 | 321                | —   | —                   | —                  |
| 150                      | 6               | 403                        | 403                 | 419                | —   | —                   | —                  |
| 200                      | 8               | 502                        | 521                 | 518                | 419                                       | 419                 | 435                |
| 250                      | 10              | 568                        | 559                 | 584                | 457                                       | 457                 | 473                |
| 300                      | 12              | 648                        | 635                 | 664                | 502                                       | 502                 | 518                |
| 350                      | 14              | 762                        | 762                 | 778                | —   | —                   | —                  |
| 400                      | 16              | 838                        | 838                 | 854                | —   | —                   | —                  |
| 450                      | 18              | 914                        | 914                 | 930                | —   | —                   | —                  |
| 500                      | 20              | 991                        | 991                 | 1010               | —   | —                   | —                  |
| 550                      | 22              | 1092                       | 1092                | 1114               | —   | —                   | —                  |
| 600                      | 24              | 1143                       | 1143                | 1165               | —   | —                   | —                  |
| 650                      | 26              | 1245                       | 1245                | 1270               | —   | —                   | —                  |
| 700                      | 28              | 1346                       | 1346                | 1372               | —   | —                   | —                  |
| 750                      | 30              | 1397                       | 1397                | 1422               | —   | —                   | —                  |
| 800                      | 32              | 1524                       | 1524                | 1553               | —   | —                   | —                  |
| 850                      | 34              | 1626                       | 1626                | 1654               | —   | —                   | —                  |
| 900                      | 36              | 1727                       | 1727                | 1756               | —   | —                   | —                  |
| 950                      | 38              | —                          | —                   | —                  | —   | —                   | —                  |
| 1000                     | 40              | —                          | —                   | —                  | —   | —                   | —                  |
| 1100                     | 42              | —                          | —                   | —                  | —   | —                   | —                  |
| 1200                     | 48              | —                          | —                   | —                  | —   | —                   | —                  |
| 1400                     | 54              | —                          | —                   | —                  | —   | —                   | —                  |
| 1500                     | 60              | —                          | —                   | —                  | —   | —                   | —                  |

Table 4 (continued)

|            |                 | Full-bore           |                     |                    |            |                 | Full-bore           |                     |                    |
|------------|-----------------|---------------------|---------------------|--------------------|------------|-----------------|---------------------|---------------------|--------------------|
| DN<br>(mm) | NPS<br>(inches) | Raised<br>face<br>A | Welding<br>end<br>B | Ring<br>joint<br>C | DN<br>(mm) | NPS<br>(inches) | Raised<br>face<br>A | Welding<br>End<br>B | Ring<br>joint<br>C |
|            |                 | PN 64 (Class 400)   |                     |                    |            |                 | PN 100 (Class 600)  |                     |                    |
| 50         | 2               | —                   | —                   | —                  | 50         | 2               | 292                 | 292                 | 295                |
| 65         | 2½              | —                   | —                   | —                  | 65         | 2½              | 330                 | 330                 | 333                |
| 80         | 3               | —                   | —                   | —                  | 80         | 3               | 356                 | 356                 | 359                |
| 100        | 4               | 406                 | 406                 | 410                | 100        | 4               | 432                 | 432                 | 435                |
| 150        | 6               | 495                 | 495                 | 498                | 150        | 6               | 559                 | 559                 | 562                |
| 200        | 8               | 597                 | 597                 | 600                | 200        | 8               | 660                 | 660                 | 664                |
| 250        | 10              | 673                 | 673                 | 676                | 250        | 10              | 787                 | 787                 | 791                |
| 300        | 12              | 762                 | 762                 | 765                | 300        | 12              | 838                 | 838                 | 841                |
| 350        | 14              | 826                 | 826                 | 829                | 350        | 14              | 889                 | 889                 | 892                |
| 400        | 16              | 902                 | 902                 | 905                | 400        | 16              | 991                 | 991                 | 994                |
| 450        | 18              | 978                 | 978                 | 981                | 450        | 18              | 1092                | 1092                | 1095               |
| 500        | 20              | 1054                | 1054                | 1060               | 500        | 20              | 1194                | 1194                | 1200               |
| 550        | 22              | 1143                | 1143                | 1153               | 550        | 22              | 1295                | 1295                | 1305               |
| 600        | 24              | 1232                | 1232                | 1241               | 600        | 24              | 1397                | 1397                | 1407               |
| 650        | 26              | 1308                | 1308                | 1321               | 650        | 26              | 1448                | 1448                | 1461               |
| 700        | 28              | 1397                | 1397                | 1410               | 700        | 28              | 1549                | 1549                | 1562               |
| 750        | 30              | 1524                | 1524                | 1537               | 750        | 30              | 1651                | 1651                | 1664               |
| 800        | 32              | 1651                | 1651                | 1667               | 800        | 32              | 1778                | 1778                | 1794               |
| 850        | 34              | 1778                | 1778                | 1794               | 850        | 34              | 1930                | 1930                | 1946               |
| 900        | 36              | 1880                | 1880                | 1895               | 900        | 36              | 2083                | 2083                | 2099               |
| 950        | 38              | —                   | —                   | —                  | 950        | 38              | —                   | —                   | —                  |
| 1000       | 40              | —                   | —                   | —                  | 1000       | 40              | —                   | —                   | —                  |
| 1100       | 42              | —                   | —                   | —                  | 1100       | 42              | —                   | —                   | —                  |
| 1200       | 48              | —                   | —                   | —                  | 1200       | 48              | —                   | —                   | —                  |

Table 4 (concluded)

|                            |                 | Full-bore           |                     |                    |
|----------------------------|-----------------|---------------------|---------------------|--------------------|
| DN<br>(mm)                 | NPS<br>(inches) | Raised<br>face<br>A | Welding<br>end<br>B | Ring<br>joint<br>C |
| <b>PN 150 (Class 900)</b>  |                 |                     |                     |                    |
| 50                         | 2               | 368                 | 368                 | 371                |
| 65                         | 2½              | 419                 | 419                 | 422                |
| 80                         | 3               | 381                 | 381                 | 384                |
| 100                        | 4               | 457                 | 457                 | 460                |
| 150                        | 6               | 610                 | 610                 | 613                |
| 200                        | 8               | 737                 | 737                 | 740                |
| 250                        | 10              | 838                 | 838                 | 841                |
| 300                        | 12              | 965                 | 965                 | 968                |
| 350                        | 14              | 1 029               | 1 029               | 1 038              |
| 400                        | 16              | 1 130               | 1 130               | 1 140              |
| 450                        | 18              | 1 219               | 1 219               | 1 232              |
| 500                        | 20              | 1 321               | 1 321               | 1 334              |
| 550                        | 22              | —                   | —                   | —                  |
| 600                        | 24              | 1 549               | 1 549               | 1 568              |
| 650                        | 26              | —                   | —                   | —                  |
| 700                        | 28              | —                   | —                   | —                  |
| 750                        | 30              | —                   | —                   | —                  |
| 800                        | 32              | —                   | —                   | —                  |
| 850                        | 34              | —                   | —                   | —                  |
| 900                        | 36              | —                   | —                   | —                  |
| <b>PN 420 (Class 2500)</b> |                 |                     |                     |                    |
| 50                         | 2               | 451                 | 451                 | 454                |
| 65                         | 2½              | 508                 | 508                 | 540                |
| 80                         | 3               | 578                 | 578                 | 584                |
| 100                        | 4               | 673                 | 673                 | 683                |
| 150                        | 6               | 914                 | 914                 | 927                |
| 200                        | 8               | 1 022               | 1 022               | 1 038              |
| 250                        | 10              | 1 270               | 1 270               | 1 292              |
| 300                        | 12              | 1 422               | 1 422               | 1 445              |

|                            |                 | Full-bore           |                     |                    |
|----------------------------|-----------------|---------------------|---------------------|--------------------|
| DN<br>(mm)                 | NPS<br>(inches) | Raised<br>face<br>A | Welding<br>End<br>B | Ring<br>joint<br>C |
| <b>PN 250 (Class 1500)</b> |                 |                     |                     |                    |
| 50                         | 2               | 368                 | 368                 | 371                |
| 65                         | 2½              | 419                 | 419                 | 422                |
| 80                         | 3               | 470                 | 470                 | 473                |
| 100                        | 4               | 546                 | 546                 | 549                |
| 150                        | 6               | 705                 | 705                 | 711                |
| 200                        | 8               | 832                 | 832                 | 841                |
| 250                        | 10              | 991                 | 991                 | 1 000              |
| 300                        | 12              | 1 130               | 1 130               | 1 146              |
| 350                        | 14              | 1 257               | 1 257               | 1 276              |
| 400                        | 16              | 1 384               | 1 384               | 1 407              |

**Table 5—Swing check valves, reduced- and full-opening types—Face-to-face (A) and end-to-end (B and C) dimensions (mm)**

|            |                 | PN 20 (Class 150)   |                     |                    | PN 50 (Class 300)   |                     |                    | PN 64 (Class 400)   |                     |                    | PN 100 (Class 600)  |                     |                    |
|------------|-----------------|---------------------|---------------------|--------------------|---------------------|---------------------|--------------------|---------------------|---------------------|--------------------|---------------------|---------------------|--------------------|
| DN<br>(mm) | NPS<br>(inches) | Raised<br>face<br>A | Welding<br>end<br>B | Ring<br>joint<br>C | Raised<br>face<br>A | Welding<br>end<br>B | Ring<br>joint<br>C | Raised<br>face<br>A | Welding<br>end<br>B | Ring<br>joint<br>C | Raised<br>face<br>A | Welding<br>End<br>B | Ring<br>joint<br>C |
| 50         | 2               | 203                 | 203                 | 216                | 267                 | 267                 | 283                | 292                 | 292                 | 295                | 292                 | 292                 | 295                |
| 65         | 2 1/2           | 216                 | 216                 | 229                | 292                 | 292                 | 308                | 330                 | 330                 | 333                | 330                 | 330                 | 333                |
| 80         | 3               | 241                 | 241                 | 254                | 318                 | 318                 | 333                | 356                 | 356                 | 359                | 356                 | 356                 | 359                |
| 100        | 4               | 292                 | 292                 | 305                | 356                 | 356                 | 371                | 406                 | 406                 | 410                | 432                 | 432                 | 435                |
| 150        | 6               | 356                 | 356                 | 368                | 445                 | 445                 | 460                | 495                 | 495                 | 498                | 559                 | 559                 | 562                |
| 200        | 8               | 495                 | 495                 | 508                | 533                 | 533                 | 549                | 597                 | 597                 | 600                | 660                 | 660                 | 664                |
| 250        | 10              | 622                 | 622                 | 635                | 622                 | 622                 | 638                | 673                 | 673                 | 676                | 787                 | 787                 | 791                |
| 300        | 12              | 699                 | 699                 | 711                | 711                 | 711                 | 727                | 762                 | 762                 | 765                | 838                 | 838                 | 841                |
| 350        | 14              | 787                 | 787                 | 800                | 838                 | 838                 | 854                | 889                 | 889                 | 892                | 889                 | 889                 | 892                |
| 400        | 16              | 864                 | 864                 | 876                | 864                 | 864                 | 879                | 902                 | 902                 | 905                | 991                 | 991                 | 994                |
| 450        | 18              | 978                 | 978                 | 991                | 978                 | 978                 | 994                | 1 016               | 1 016               | 1 019              | 1 092               | 1 092               | 1 095              |
| 500        | 20              | 978                 | 978                 | 991                | 1 016               | 1 016               | 1 035              | 1 054               | 1 054               | 1 060              | 1 194               | 1 194               | 1 200              |
| 550        | 22              | 1 067               | 1 067               | 1 080              | 1 118               | 1 118               | 1 140              | 1 143               | 1 143               | 1 153              | 1 295               | 1 295               | 1 305              |
| 600        | 24              | 1 295               | 1 295               | 1 308              | 1 346               | 1 346               | 1 368              | 1 397               | 1 397               | 1 407              | 1 397               | 1 397               | 1 407              |
| 650        | 26              | 1 295               | 1 295               | —                  | 1 346               | 1 346               | 1 372              | 1 397               | 1 397               | 1 410              | 1 448               | 1 448               | 1 461              |
| 700        | 28              | 1 448               | 1 448               | —                  | 1 499               | 1 499               | 1 524              | 1 600               | 1 600               | 1 613              | 1 600               | 1 600               | 1 613              |
| 750        | 30              | 1 524               | 1 524               | —                  | 1 594               | 1 594               | 1 619              | 1 651               | 1 651               | 1 664              | 1 651               | 1 651               | 1 664              |
| 900        | 36              | 1 956               | 1 956               | —                  | 2 083               | 2 083               | —                  | 2 083               | 2 083               | —                  | 2 083               | 2 083               | —                  |
| 950        | 38              | —                   | —                   | —                  | —                   | —                   | —                  | —                   | —                   | —                  | —                   | —                   | —                  |
| 1 000      | 40              | —                   | —                   | —                  | —                   | —                   | —                  | —                   | —                   | —                  | —                   | —                   | —                  |
| 1 100      | 42              | —                   | —                   | —                  | —                   | —                   | —                  | —                   | —                   | —                  | —                   | —                   | —                  |
| 1 200      | 48              | —                   | —                   | —                  | —                   | —                   | —                  | —                   | —                   | —                  | —                   | —                   | —                  |
| 1 400      | 54              | —                   | —                   | —                  | —                   | —                   | —                  | —                   | —                   | —                  | —                   | —                   | —                  |
| 1 500      | 60              | —                   | —                   | —                  | —                   | —                   | —                  | —                   | —                   | —                  | —                   | —                   | —                  |

Table 5 (concluded)

|            |                 | PN 150 (Class 900) |                |               | PN 250 (Class 1500) |                |               | PN 420 (Class 2500) |                |               |
|------------|-----------------|--------------------|----------------|---------------|---------------------|----------------|---------------|---------------------|----------------|---------------|
| DN<br>(mm) | NPS<br>(inches) | Raised<br>face     | Welding<br>end | Ring<br>joint | Raised<br>face      | Welding<br>end | Ring<br>joint | Raised<br>face      | Welding<br>End | Ring<br>joint |
|            |                 | A                  | B              | C             | A                   | B              | C             | A                   | B              | C             |
| 50         | 2               | 368                | 368            | 371           | 368                 | 368            | 371           | 451                 | 451            | 454           |
| 65         | 2½              | 419                | 419            | 422           | 419                 | 419            | 422           | 508                 | 508            | 514           |
| 80         | 3               | 381                | 381            | 384           | 470                 | 470            | 473           | 578                 | 578            | 584           |
| 100        | 4               | 457                | 457            | 460           | 546                 | 546            | 549           | 673                 | 673            | 683           |
| 150        | 6               | 610                | 610            | 613           | 705                 | 705            | 711           | 914                 | 914            | 927           |
| 200        | 8               | 737                | 737            | 740           | 832                 | 832            | 841           | 1 022               | 1 022          | 1 038         |
| 250        | 10              | 838                | 838            | 841           | 991                 | 991            | 1 000         | 1 270               | 1 270          | 1 292         |
| 300        | 12              | 965                | 965            | 968           | 1 130               | 1 130          | 1 146         | 1 422               | 1 422          | 1 445         |
| 350        | 14              | 1 029              | 1 029          | 1 038         | 1 257               | 1 257          | 1 276         | —                   | —              | —             |
| 400        | 16              | 1 130              | 1 130          | 1 140         | 1 384               | 1 384          | 1 407         | —                   | —              | —             |
| 450        | 18              | 1 219              | 1 219          | 1 232         | 1 537               | 1 537          | 1 559         | —                   | —              | —             |
| 500        | 20              | 1 321              | 1 321          | 1 334         | 1 664               | 1 664          | 1 686         | —                   | —              | —             |
| 600        | 24              | 1 549              | 1 549          | 1 568         | 1 943               | 1 943          | 1 972         | —                   | —              | —             |



**Table 6—Single- and dual-plate, long- and short-pattern, wafer-type check valves—Face-to-face dimensions (mm)**

| DN<br>(mm) | NPS<br>(inches) | PN 20<br>(Class 150) |              | PN 50<br>(Class 300) |              | PN 64<br>(Class 400) |              | PN 100<br>(Class 600) |              | PN 150<br>(Class 900) |              | PN 250<br>(Class 1500) |              | PN 420<br>(Class 2500) |              |
|------------|-----------------|----------------------|--------------|----------------------|--------------|----------------------|--------------|-----------------------|--------------|-----------------------|--------------|------------------------|--------------|------------------------|--------------|
|            |                 | Short-pattern        | Long-pattern | Short-pattern        | Long-pattern | Short-pattern        | Long-pattern | Short-pattern         | Long-pattern | Short-pattern         | Long-pattern | Short-pattern          | Long-pattern | Short-pattern          | Long-pattern |
| 50         | 2               | 19                   | 60           | 19                   | 60           | 19                   | 60           | 19                    | 60           | 19                    | 70           | 19                     | 70           | NOTE                   | 70           |
| 65         | 2 1/2           | 19                   | 67           | 19                   | 67           | 19                   | 67           | 19                    | 67           | 19                    | 83           | 19                     | 83           | NOTE                   | 83           |
| 80         | 3               | 19                   | 73           | 19                   | 73           | 19                   | 73           | 19                    | 73           | 19                    | 83           | 22                     | 83           | NOTE                   | 86           |
| 100        | 4               | 19                   | 73           | 19                   | 73           | 22                   | 79           | 22                    | 79           | 22                    | 102          | 32                     | 102          | NOTE                   | 105          |
| 150        | 6               | 19                   | 98           | 22                   | 98           | 25                   | 137          | 29                    | 137          | 35                    | 159          | 44                     | 159          | NOTE                   | 159          |
| 200        | 8               | 29                   | 127          | 29                   | 127          | 32                   | 165          | 38                    | 165          | 44                    | 206          | 57                     | 206          | NOTE                   | 206          |
| 250        | 10              | 29                   | 146          | 38                   | 146          | 51                   | 213          | 57                    | 213          | 57                    | 241          | 73                     | 248          | NOTE                   | 250          |
| 300        | 12              | 38                   | 181          | 51                   | 181          | 57                   | 229          | 60                    | 229          | NOTE                  | 292          | NOTE                   | 305          | NOTE                   | 305          |
| 350        | 14              | 44                   | 184          | 51                   | 222          | 64                   | 273          | 67                    | 273          | NOTE                  | 356          | NOTE                   | 356          | —                      | —            |
| 400        | 16              | 51                   | 191          | 51                   | 232          | 64                   | 305          | 73                    | 305          | NOTE                  | 384          | NOTE                   | 384          | —                      | —            |
| 450        | 18              | 60                   | 203          | 76                   | 264          | 83                   | 362          | 83                    | 362          | NOTE                  | 451          | NOTE                   | 468          | —                      | —            |
| 500        | 20              | 64                   | 219          | 83                   | 292          | 89                   | 368          | 92                    | 368          | NOTE                  | 451          | NOTE                   | 533          | —                      | —            |
| 600        | 24              | NOTE                 | 222          | NOTE                 | 318          | NOTE                 | 394          | NOTE                  | 438          | NOTE                  | 495          | NOTE                   | 559          | —                      | —            |
| 750        | 30              | —                    | —            | —                    | —            | —                    | —            | —                     | —            | —                     | —            | —                      | —            | —                      | —            |
| 900        | 36              | —                    | —            | —                    | —            | —                    | —            | —                     | —            | —                     | —            | —                      | —            | —                      | —            |
| 1 100      | 42              | —                    | —            | —                    | —            | —                    | —            | —                     | —            | —                     | —            | —                      | —            | —                      | —            |
| 1 200      | 48              | —                    | —            | —                    | —            | —                    | —            | —                     | —            | —                     | —            | —                      | —            | —                      | —            |
| 1 400      | 54              | —                    | —            | —                    | —            | —                    | —            | —                     | —            | —                     | —            | —                      | —            | —                      | —            |
| 1 500      | 60              | —                    | —            | —                    | —            | —                    | —            | —                     | —            | —                     | —            | —                      | —            | —                      | —            |

NOTE Dimensions to be established by agreement.

**6.4 Minimum-bore full-opening valves**

Minimum bores for full-opening valves shall not be less than those specified in Table 1.

**6.5 Valve operation**

The purchaser should specify the maximum pressure differential (MPD) at which the valve is required to be opened by the lever, gearbox or actuator. If not specified, the pressure rating as determined in accordance with 6.1 for material at 38°C (100°F) shall be the MPD.

The manufacturer shall provide the following data to the purchaser:

- the flow coefficient  $K_v$ ;
- the breakaway thrust or torque for new valve;
- the maximum allowable stem thrust or torque on the valve and, if applicable, the drive train.

**6.6 Piggging**

The purchaser shall specify the requirements for piggability of the valves. Clause A.4 may be used to assist.

## 6.7 Valve ends

### 6.7.1 Flanged ends

Standard end flanges shall be furnished with a raised face or ring joint faces (raised face or full face). Dimensions, tolerances and finishes, including drilling templates, flange facing, spot facing and back facing, shall be in accordance with:

- ASME B16.5 for sizes up to and including DN 600 (NPS 24), except DN 550 (NPS 22);
- MSS SP-44 for DN 550 (NPS 22);
- ASME B16.47 Series A for DN 650 (NPS 26) and larger sizes.

### 6.7.2 Welding ends

Welding ends shall conform to Figures 434.86 (a) (1) and (2) of ASME B31.4 or Figures 14 and 15 of ASME B31.8 unless otherwise agreed. In the case of a heavy-wall valve body, the outside profile may be tapered at 30° and then to 45° as illustrated in Figure 1 of ASME B16.25.

The purchaser shall specify the outside diameter, wall thickness, material grade, SMYS and special chemistry of the mating pipe, and whether cladding has been applied.

### 6.7.3 Special flanges and mechanical joints

Other end connections, such as special flanges or mechanical joints, may be specified by the purchaser.

## 6.8 Pressure relief

The manufacturer shall determine whether fluid can become trapped in the body cavity in the open- and/or closed-valve position.

If fluid trapping is possible, then valves for gas service, unless otherwise specified by the purchaser, and liquid service shall be provided with an automatic cavity pressure relief.

Cavity relief, when required, shall prevent the pressure in the cavity from exceeding 1,33 times the valve pressure rating determined in accordance with 6.1 for material at 38°C (100°F). External cavity relief valves shall be DN 15 (NPS 1/2) or larger.

## 6.9 Bypass, drain and vent connections

Bypass, drain and vent connections and plug entries shall be drilled and threaded unless otherwise specified. The purchaser may specify other types of connections, such as welded or flanged.

Threads shall be either tapered and capable of providing a pressure-tight seal or parallel-threaded. Connections or plugs with parallel threads shall have a head section for trapping and retaining a sealing member suitable for the specified valve service.

Thread sizes shall be in accordance with Table 7. Thread forms shall be in accordance with ASME B1.1, ASME B1.20.1, ISO 228-1, ISO 228-2 or ISO 7-1.

**Table 7 — Thread sizes for bypass, drain and vent connections**

| Nominal size of connection |                                | Thread size          |
|----------------------------|--------------------------------|----------------------|
| DN (mm)                    | NPS (inches)                   | mm (inches)          |
| 15 – 40                    | $\frac{1}{2}$ – $1\frac{1}{2}$ | 8 ( $\frac{1}{4}$ )  |
| 50 – 100                   | 2 – 4                          | 15 ( $\frac{1}{2}$ ) |
| 150 – 200                  | 6 – 8                          | 20 ( $\frac{3}{4}$ ) |
| $\geq 250$                 | $\geq 10$                      | 25 (1)               |

### 6.10 Handwheels and wrenches (levers)

Wrenches for valves shall either be of an integral design or consist of a head which fits on the stem and is designed to take an extended handle. The head design shall allow permanent attachment of the extended section if specified by the purchaser.

The maximum force required at the handwheel or wrench to apply the breakaway torque or thrust shall not exceed 360 N.

Wrenches shall not be longer than twice the face-to-face or end-to-end dimension of the valve.

Handwheel diameter(s) shall not exceed the face-to-face or end-to-end length of the valve or 1 000 mm, whichever is the smaller, unless otherwise agreed. Except for valve sizes DN 40 (NPS  $1\frac{1}{2}$ ) and smaller, spokes shall not extend beyond the perimeter of the handwheel unless otherwise agreed.

When specified by the purchaser, the handwheel of the gearbox input shaft shall be provided with a torque-limiting device, such as a shear pin, to prevent damage to the drive train.

### 6.11 Locking devices

Valves shall be supplied with locking devices if specified by the purchaser. Locking devices for check valves shall be designed to lock the valve in the open position only.

Locking devices for other types of valve shall be designed to lock the valve in the open and/or closed position.

### 6.12 Position indicators

Valves fitted with manual or powered actuators shall be furnished with a visible indicator to show the open and the closed position of the obturator.

For plug and ball valves, the wrench and/or the position indicator shall be in line with the pipeline when the valve is open and transverse when the valve is closed. The design shall be such that the component(s) of the indicator and/or wrench cannot be assembled to falsely indicate the valve position.

Valves without position stops shall have provision for the verification of open and close alignment with the operator/actuator removed.

## 6.13 Operators and stem extensions

### 6.13.1 Misalignment

Misalignment or improper assembly of components shall be prevented by suitable means, such as a dowel pin or fitting bolt, which ensure the unique location of manual or powered operators and stem extension assemblies.

### 6.13.2 Sealing

External connections shall be sealed, for example with gaskets or O-rings, to prevent external contaminants entering the mechanism.

### 6.13.3 Overpressure protection

Operators and stem extension assemblies shall be provided with a means of preventing pressure build-up in the mechanism resulting from stem or bonnet seal leakage.

## 6.14 Sealant injection

Seat and/or stem sealant injection shall be provided when specified.

## 6.15 Lifting lugs

Valves of size DN 200 (NPS 8) and larger shall be provided with lifting lugs.

## 6.16 Actuators

Actuators may be powered by electric, hydraulic or pneumatic means.

The interface between actuators and valve bonnet or stem extension assemblies shall be designed to prevent misalignment or improper assembly of the components.

The interface between actuators and valve bonnet or stem extension assemblies shall be sealed with gaskets or O-rings to prevent external contaminants from entering the assembly.

Means shall be provided of preventing pressure build-up in the actuator from stem or bonnet seal leakage.

The output of the actuator shall not exceed the maximum load capacity of the valve drive train.

NOTE Typical valve-to-actuator interfaces are given in ISO 5211.

## 6.17 Drive trains

### 6.17.1 Design thrust or torque

The design thrust or torque for all drive train calculations shall be at least two times the breakaway thrust or torque.

NOTE This factor of safety is to allow for thrust or torque increase in service due to infrequent cycling, low-temperature operation and the adverse effect of debris.

### 6.17.2 Allowable stresses

Tensile stresses in drive train components, including stem extensions, shall not exceed 67% of SMYS when delivering the design thrust or torque. Shear, torsion and bearing stresses shall not exceed the limits specified in ASME Code Section VIII, Division 2, Part AD-132.

A strength efficiency factor of 0,75 shall be used for fillet welds.

### 6.17.3 Allowable deflections

For ball valves, the total torsional deflection of the extended drive train when delivering the design torque shall not exceed the overlap contact angle between the seat and obturator.

Deflections of the extended drive train shall not prevent the obturator from reaching the fully closed position.

### 6.18 Stem retention

Valves shall be designed with a stem anti-blow-out device to prevent stem ejection by internal pressure when the stem packing and/or retainer has been removed.

### 6.19 Fire safety

If specified by the purchaser, fire resistance certification of the design shall be provided, in accordance with clause A.5.

### 6.20 Anti-static device

If specified by the purchaser, valves shall be provided with an anti-static device and tested in accordance with clause C.5.

### 6.21 Design documents

The design shall be documented in a retrievable and reproducible form.

### 6.22 Design document review

Design documentation shall be reviewed and verified by competent personnel other than the person who performed the original design.

## 7 Materials

### 7.1 Material specification

Materials shall be procured to documented specifications.

Specifications for metallic parts shall, as a minimum, specify the requirements for:

- chemical properties;
- heat treatment;
- mechanical properties;
- testing;
- certification.

Metallic pressure-containing parts, except stems and gaskets, shall be made of materials listed in ASME B16.34 or, by agreement, an equivalent standard.

### 7.2 Service compatibility

All process-wetted parts, metallic and non-metallic, and lubricants shall be suitable for the commissioning fluids and service specified by the purchaser.

Non-metallic parts of valves intended for hydrocarbon gas service at pressures of PN 100 (Class 600) or above shall be resistant to explosive decompression.

### 7.3 Forged parts

Forged pressure-containing parts shall be forged close to the finished shape and size.

### 7.4 Welding ends

The chemistry of carbon steel welding ends shall meet the following requirements:

- a) The carbon content shall not exceed 0,23% by mass in the ladle (heat) analysis or 0,25% by mass in the product (check) analysis.
- b) The maximum content of both sulfur and phosphorus shall not exceed 0,035% by mass.
- c) The carbon equivalent (CE) shall not exceed 0,43 in the ladle (heat) analysis or 0,45 in the product (check) analysis. The CE shall be calculated in accordance with the following formula:

$$CE = \% C + (\% Mn/6) + (\% Cr + \% Mo + \% V)/5 + (\% Ni + \% Cu)/15$$

The chemistry of austenitic stainless steels for welding ends shall meet the following requirements:

- a) The carbon content shall not exceed 0,03% by mass, except under the conditions outlined in b) and c) below.
- b) A carbon content of up to 0,08% by mass is permissible provided the material is stabilized with niobium and the niobium content is at least 10 times the carbon content by mass.
- c) For steels stabilized with niobium or tantalum, the combined mass of niobium and tantalum shall be at least eight times the mass of the carbon.

Requirements for the chemistry of welding ends made of other materials shall be established by agreement.

### 7.5 Toughness test requirements

All carbon and low-alloy steels for pressure-containing parts in valves with a specified design temperature below  $-29^{\circ}\text{C}$  ( $-20^{\circ}\text{F}$ ) shall be impact-tested using the Charpy V-notch technique in accordance with ISO 148 or ASTM A 370.

**NOTE** Design standards/codes or local requirements may require impact testing for minimum design temperatures higher than  $-29^{\circ}\text{C}$  ( $-20^{\circ}\text{F}$ ).

A minimum of one impact test, comprising a set of three specimens, shall be performed on a representative test bar of each heat of the material in the final heat-treated condition.

Test specimens shall be cut from a separate or attached block taken from the same heat, reduced by forging where applicable, and heat-treated in the same heat treatment batch, including stress-relieving, as the product materials except that:

- pressure-containing parts stress-relieved at or below a previous stress-relieving or tempering temperature need not be retested;
- retesting is not required after stress-relieving if the measured toughness of the material before stress-relieving is three times the required toughness.

Toughness testing may be performed during the qualification of the valve manufacturing procedure provided that the material for testing is heat-treated using the same equipment as during valve production.

The impact test temperature shall be as defined in the applicable material specifications and pipeline design standard/code.

Except for material for bolting, impact test results for full-size specimens shall meet the requirements of Table 8. Impact test results for bolting material shall meet the requirements of ASTM A 320.

**Table 8—Charpy V-notch impact requirements (full-size specimen)**

| Specified minimum tensile strength (MPa) | Average of three specimens (J) | Minimum for single specimen (J) |
|--|--------------------------------|---------------------------------|
| ≤ 586                                    | 20                             | 16                              |
| 587 – 688                                | 27                             | 20                              |
| ≥ 689                                    | 34                             | 25                              |

## 7.6 Bolting

Bolting shall be suitable for the specified valve service and pressure rating.

Bolting material with a mechanical strength above ASTM A 193 Grade B7 or hardness exceeding HRC22 shall not be used for valve applications where hydrogen embrittlement may occur, unless otherwise agreed. For example, hydrogen embrittlement can occur in buried pipelines with cathodic protection.

## 7.7 Sour service

Materials for pressure-containing and pressure-controlling parts and bolting shall meet the requirements of NACE MR 0175 if sour service is specified.

## 8 Welding

### 8.1 Qualifications

Welding, including repair welding, of pressure-containing and pressure-controlling parts shall be performed in accordance with procedures qualified to ASME Section IX or EN 288–3, and 8.2 and 8.3 of this International Standard. Welders and welding operators shall be qualified in accordance with ASME Section IX or EN 287–1.

**NOTE** The purchaser, pipeline design standards/codes, material specifications and local requirements may specify additional requirements.

The results of all qualification tests shall be documented in a procedure qualification record (PQR).

Post-weld heat treatment (PWHT) shall be performed in accordance with the relevant material specification.

**NOTE** Some pipeline-welding standards, such as BS 4515, may have more stringent requirements for the essential variables of welding. It may be necessary to provide full weld test rings, in the same heat treatment condition as the finished valve, for weld procedure qualification.

### 8.2 Impact testing

Impact testing shall be carried out for the qualification of procedures for welding on valves with a design temperature below  $-29^{\circ}\text{C}$  ( $-20^{\circ}\text{F}$ ).

**NOTE** Design code and/or local requirements may require impact testing at minimum design temperatures above  $-29^{\circ}\text{C}$  ( $-20^{\circ}\text{F}$ ).

A set of three weld metal impact specimens shall be taken from the weld metal (WM) at the location shown in Figure 12. The specimens shall be oriented with the notch perpendicular to the surface of the material.

A set of three impact specimens shall be taken from the heat-affected zone (HAZ) at the location shown in Figure 13. The notch shall be placed perpendicularly to the material surface at a location resulting in a maximum amount of HAZ material located in the resulting fracture.

HAZ tests shall be conducted for each of the materials being joined when the base materials being joined are of a different P-number and/or group number in accordance with ASME Section IX or when one or both of the base materials being joined are not listed in the P-number grouping.

Impact testing shall be performed in accordance with ISO 148 or ASTM A 370 using the Charpy V-notch technique. Specimens shall be etched to determine the location of the notch.

The impact test temperature for welds and heat-affected zones shall be at or below the minimum design temperature specified for the valve.

Impact test results for full-size specimens shall meet the requirements of Table 8.

**8.3 Hardness testing**

Hardness testing shall be carried out for the qualification of procedures for welding on pressure-containing and pressure-controlling parts in valves required to meet NACE MR 0175.

Hardness surveys shall be performed on base metal (BM), WM and HAZ as indicated in Figure 14 using the Rockwell HRC or Vickers HV<sub>10</sub> method.

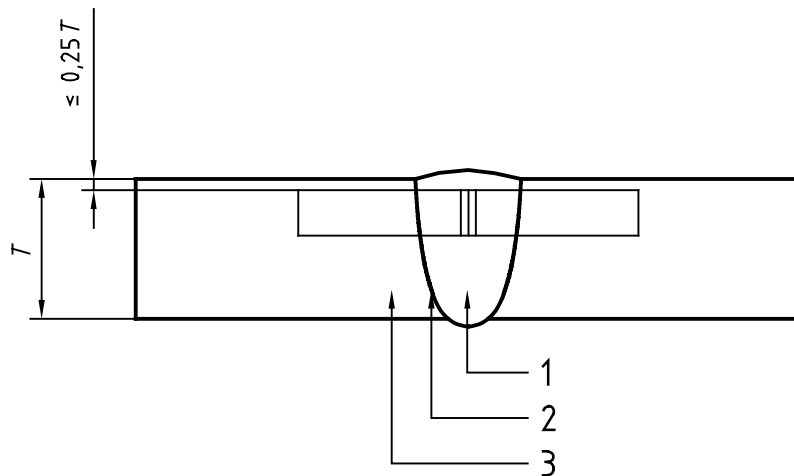

**Key**

- 1 Weld metal
- 2 Heat-affected zone
- 3 Base metal

**Figure 12—Charpy V-notch weld metal (WM) specimen location**



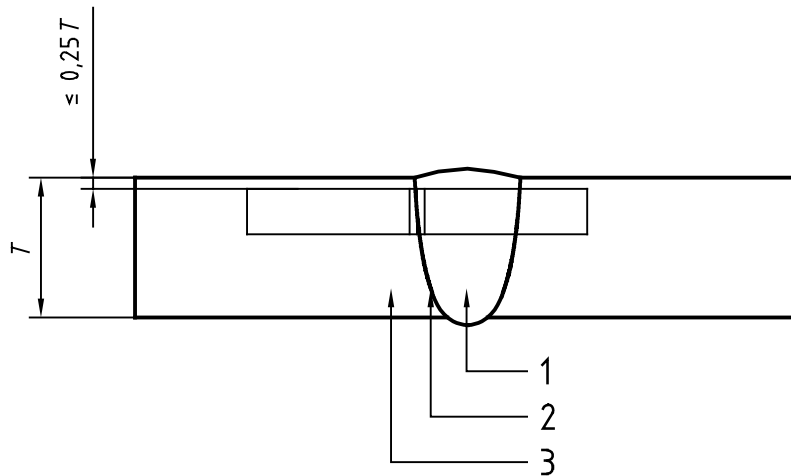

**Key**

- 1 Weld metal
- 2 Heat-affected zone
- 3 Base metal

**Figure 13—Charpy V-notch heat-affected zone (HAZ) specimen location**

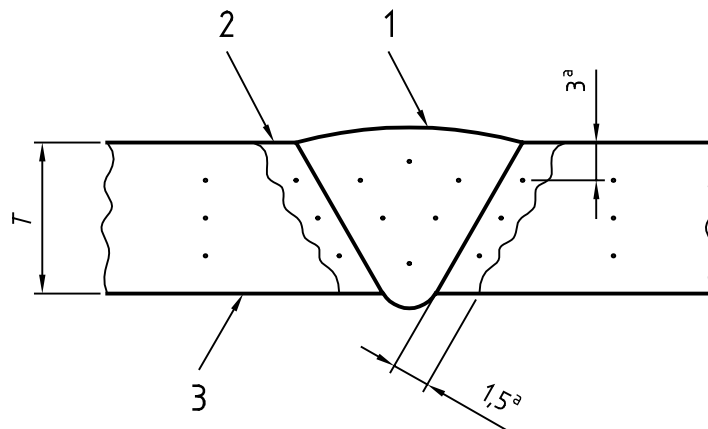

**Key**

- 1 Weld metal
- 2 Heat-affected zone
- 3 Base metal
- 4 1,5 mm (typical)
- 5 3,0 mm (typical)

**Figure 14—Hardness survey specimen location**

**9 Quality control**

**9.1 General**

This clause specifies the quality control requirements for the manufacturing of valves. The purchaser shall specify which particular supplementary NDE requirements in Annex B shall be performed.

## 9.2 Measuring and test equipment

### 9.2.1 General

Equipment used to inspect, test or examine material or equipment shall be identified, controlled and calibrated at intervals specified in the manufacturer's instructions.

### 9.2.2 Dimension-measuring equipment

Equipment for measuring dimensions shall be controlled and calibrated in accordance with methods specified in documented procedures.

### 9.2.3 Pressure-measuring devices

#### 9.2.3.1 Type and accuracy

Test pressure measuring devices shall be either pressure gauges or pressure transducers which are accurate to within  $\pm 2,0\%$  of the full-scale reading.

#### 9.2.3.2 Gauge range

Pressure measurements shall be made between 25% and 75% of the full pressure range of the measuring device.

#### 9.2.3.3 Calibration procedure

Pressure-measuring devices shall be periodically recalibrated with a master pressure-measuring device or a deadweight tester at 25%, 50%, 75% and 100% of the full pressure scale.

### 9.2.4 Temperature-measuring devices

Devices for measuring temperature, if required, shall be capable of indicating and recording temperature fluctuations of 3°C (5°F).

## 9.3 Qualification of inspection and test personnel

### 9.3.1 NDE personnel

NDE personnel shall be qualified in accordance with the requirements specified in ASNT SNT-TC-1A or EN 473 Level II as a minimum.

Personnel performing visual examinations shall have passed an annual eye examination in accordance with ASNT SNT-TC-1A or EN 473 within the previous twelve months.

### 9.3.2 Welding inspectors

Personnel performing visual inspection of welding operations and completed welds shall be qualified and certified to the requirements of AWS QC1, or equivalent, or a manufacturer's documented training programme.

## 9.4 NDE of repair welding

After defect removal, the excavated area shall be examined by magnetic particle (MT) or liquid penetrant (PT) methods prior to starting repair welding.

Repair welds on pressure-containing parts shall be examined using MT or PT methods. Acceptance criteria shall be specified in documented procedures.

The supplementary NDE requirements in Annex B, if specified by the purchaser, shall also apply to repair welding.

## 10 Pressure testing

### 10.1 General

Each valve shall be tested in accordance with this clause prior to shipment. The purchaser shall specify which particular supplementary tests in Annex C shall be performed, together with the frequency of testing.

Testing shall be performed in the sequence used in this clause for specifying the test requirements. Shell pressure testing shall be carried out before painting of the valves.

Test fluids shall be fresh water which may contain a corrosion inhibitor and, by agreement, antifreeze. The chloride content of test water for austenitic and ferritic-austenitic (duplex) stainless-steel body/bonnet valves shall not exceed 30 µg/g (30 ppm).

Valves shall be tested with the seating and sealing surfaces free from sealant except where the sealant is the primary means of sealing.

Tests specified with the valve half-open may also be performed with the valve fully open provided the body cavity is simultaneously filled and pressurized through a cavity connection.

Methods for monitoring pressures and/or leakage shall be adequate also when valve body connections are not available for direct monitoring.

A sufficient stabilization period shall be allowed for all pressure tests.

Pressure testing shall be performed in accordance with documented procedures.

### 10.2 Stem backseat test

Unless otherwise agreed, stem backseat testing shall be performed prior to shell testing.

Where a valve has a stem backseat feature, testing of the backseat shall commence with the seat free. Self-energized packing or seals shall be removed unless a test port is provided for this test.

The valves shall be filled with the ends closed off and the obturator in the partially open position until leakage of the test fluid around the stem is observed. The backseat shall then be closed and a minimum pressure of 1,1 times the pressure rating determined in accordance with 6.1 for material at 38°C (100°F) is applied for the duration specified in Table 9.

Monitoring for leakage shall be through a test access port or by monitoring leakage around the loosened packing.

No visible leakage is permitted at this test pressure.

**Table 9—Minimum duration of stem backseat tests**

| Valve size |                 | Test duration<br>(minutes) |
|------------|-----------------|----------------------------|
| DN<br>(mm) | NPS<br>(inches) |                            |
| ≤ 100      | ≤ 4             | 2                          |
| ≥ 150      | ≥ 6             | 5                          |

### 10.3 Hydrostatic shell test

Hydrostatic shell testing shall be performed on the fully assembled valve prior to painting.

Valves shall be closed off and the obturator placed in the partially open position during the test. If specified by the purchaser, the method of closing the ends shall permit the transmission of the full-pressure force acting on the end blanks to the valve body. Where present, external relief valves shall be removed and their connections plugged.

The test pressure shall be 1,5 or more times the pressure rating determined in accordance with 6.1 for material at 38°C (100°F). The duration shall not be less than that specified in Table 10.

**Table 10—Minimum duration of hydrostatic shell tests**

| Valve size |                 | Test duration<br>(minutes) |
|------------|-----------------|----------------------------|
| DN<br>(mm) | NPS<br>(inches) |                            |
| 15 – 100   | 1/2 – 4         | 2                          |
| 150 – 250  | 6 – 10          | 5                          |
| 300 – 450  | 12 – 18         | 15                         |
| ≥ 500      | ≥ 20            | 30                         |

No visible leakage is permitted during the hydrostatic shell test.

After hydrostatic shell testing, external relief valves shall be (re)fitted to the valve. The connection to the valve body shall be tested at 95% of the set pressure of the relief valve for 2 minutes for valve sizes up to and including DN 100 (NPS 4), and 5 minutes for valve sizes DN 150 (NPS 6) and larger. The relief valve connection shall be free of visible leakage during this period.

Where provided, the external relief valve shall be set to relieve at the specified pressure and tested. The set pressure of relief valves shall be between 1,1 and 1,33 times the valve pressure rating determined in accordance with 6.1 for material at 38°C (100°F).

### 10.4 Hydrostatic seat test

#### 10.4.1 Alternative test

High-pressure gas seat testing in accordance with clause C.4 may be performed in lieu of the hydrostatic seat test described below.

#### 10.4.2 Preparation

Lubricants shall be removed from seats and obturator sealing surfaces except, by agreement, for assembly lubricants for metal-to-metal contact surfaces.

#### 10.4.3 Test pressure and duration

The test pressure for all seat tests shall not be less than 1,1 times the pressure rating determined in accordance with 6.1 for material at 38°C (100°F). The test duration shall be in accordance with Table 11.

Table 11—Minimum duration of seat tests

| Valve size |                 | Test duration<br>(minutes) |
|------------|-----------------|----------------------------|
| DN<br>(mm) | NPS<br>(inches) |                            |
| 15 – 100   | 1/2 – 4         | 2                          |
| ≥ 150      | ≥ 6             | 5                          |

#### 10.4.4 Acceptance criteria

Leakage for soft-seated valves and lubricated plug valves shall not exceed ISO 5208 Rate A (no visible leakage). For metal-seated valves the leakage rate shall not exceed ISO 5208 Rate D, except that the leakage rate during the seat test in 10.4.5.5.2 shall not be more than two times ISO 5208 Rate D unless otherwise specified. The test procedures for various types of block valve are given in 10.4.5.

#### 10.4.5 Test procedures for block valves

##### 10.4.5.1 Uni-directional

With the valve half-open, the valve and its cavity shall be completely filled with test fluid. The valve shall then be closed and the test pressure applied to the appropriate end of the valve.

Leakage from each seat shall be monitored via the valve body cavity vent or drain connection. For valves without a body cavity connection, seat leakage shall be monitored from each seat at the respective downstream end of the valve (the valve end downstream of the pressurized test fluid).

##### 10.4.5.2 Bi-directional

With the valve half-open, the valve and its cavity shall be completely filled with test fluid. The valve shall then be closed and the test pressure applied successively to both ends of the valve.

Seat leakage shall be monitored from each seat via the valve body cavity vent or drain connection. For valves without a body cavity vent or drain connection, seat leakage shall be monitored from the respective downstream end of the valve.

##### 10.4.5.3 Twin-seat, both seats bi-directional

Each seat shall be tested in both directions.

Cavity relief valves shall be removed if fitted. The valve and cavity shall be filled with test fluid, with the valve half-open, until the test fluid overflows through the cavity relief connection.

To test for seat leakage in the direction of the cavity, the valve shall be closed. The test pressure shall be applied successively to each valve end to test each seat separately from the upstream side. Leakage shall be monitored via the valve cavity pressure relief connection.

Thereafter, each seat shall be tested as a downstream seat. Both ends of the valve shall be drained and the valve cavity filled with test fluid. Pressure shall then be applied whilst monitoring leakage through each seat at both ends of the valve.

##### 10.4.5.4 Twin-seat, one seat uni-directional and one seat bi-directional

###### 10.4.5.4.1 Uni-directional seat

With the valve half-open, the valve and the test cavity shall be completely filled with test fluid until fluid overflows through the valve cavity vent connection. The valve shall then be closed and the vent valve on the test closure opened to allow fluid to overflow, or the test closure on the downstream end of the valve removed. The test pressure shall then be applied to the upstream end (uni-directional seat end) and leakage monitored from the cavity connection. If leakage is also occurring through the downstream seat, the upstream seat leakage shall be taken as the sum of the leakage measured from the cavity and the downstream connections.

#### 10.4.5.4.2 Bi-directional seat

The test in 10.4.5.4.1 shall be repeated to test the bi-directional seat in its upstream-sealing direction.

To test the bi-directional seat in its downstream-sealing direction, both ends of the valve shall be blanked off. With the valve half-open, the valve shall be completely filled with test fluid and pressurized to the test pressure. The valve shall then be closed and test fluid allowed to overflow from a connection on the test closure fitted to the end of the valve at the bi-directional seat end (i.e., downstream of the bi-directional seat). The test pressure shall be maintained on the cavity connection whilst monitoring seat leakage of the bi-directional seat at the overflow connection on the downstream test closure.

#### 10.4.5.5 Double-block-and-bleed valves

##### 10.4.5.5.1 Single-seat test

With the valve half-open, the valve and its cavity shall be completely filled with test fluid. The valve shall then be closed and the valve body vent valve opened to allow excess test fluid to overflow from the valve cavity test connection. The test pressure shall then be applied to one end of the valve and the pressure released at the other end. This test shall be repeated for the other valve end.

Seat tightness shall be monitored during each test via overflow from the valve cavity connection.

##### 10.4.5.5.2 Double-block seat test

With the valve half-open, the valve and its cavity shall be completely filled with test fluid. The valve shall then be closed and the valve body vent valve opened to allow excess test fluid to overflow from the valve cavity test connection. The test pressure shall be applied simultaneously from both valve ends.

Seat tightness shall be monitored via overflow through the valve cavity connection.

The tests in 10.4.5.5 may be performed in any order by the manufacturer.

#### 10.4.5.6 Check valves

The pressure shall be applied in the direction of the required flow blockage.

#### 10.4.5.7 Installation of body connections after testing

Pressure-containing parts, such as vent/or drain plug(s) and cavity relief valves, shall be fitted, on completion of testing, in accordance with documented procedures.

### 10.5 Draining

Valves shall be drained of test fluids and, where applicable, lubricated before shipment.

## 11 Marking

### 11.1 Requirements

Valves shall be marked in accordance with Table 12.

On valves whose size or shape limits the body markings, they may be omitted in the following order:

- size;
- rating;
- material;
- manufacturer's name or trademark.

The nameplate and serial number may be omitted for valves smaller than DN 50 (NPS 2). The purchaser may specify requirements for the marking of valve components.

For valves with one seat uni-directional and one seat bi-directional only, the directions of both seats shall be specified on a separate identification plate as illustrated in Figure 15. In Figure 15, one symbol indicates the bi-directional seat and the other symbol indicates the uni-directional seat.

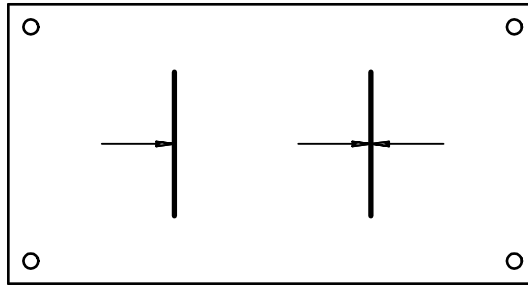

**Figure 15—Typical identification plate for valve with one seat uni-directional and one seat bi-directional**

**Table 12—Valve marking**

| <b>Marking</b>   | <b>Application</b>   |
|--|--|
| 1. Manufacturer's name or trademark.....   | On both body and nameplate   |
| 2. Pressure class.....   | On both body and nameplate   |
| 3. Pressure/temperature rating:.....   | On nameplate   |
| a) Maximum operating pressure at maximum operating temperature   |  |
| b) Maximum operating pressure at minimum operating temperature   |  |
| 4. Face-to-face/end-to-end dimension (6.3).....  | On nameplate   |
| 5. Body material designation:  |  |
| Material symbol, e.g., AISI, ASME, ASTM or ISO .....   | On both body and nameplate. Melt identification (e.g., cast or heat number) on nameplate only. |
| NOTE When body is fabricated of more than one type of steel, the end connection material governs marking.    |  |
| 6. Bonnet/cover material designation:  |  |
| Material symbol e.g., AISI, ASME, ASTM, ISO .....  | On bonnet/cover [including melt identification (e.g., heat number)]                            |
| 7. Trim identification:  |  |
| Symbols indicating material of stem and sealing faces of closure members if different from that of body..... | On nameplate   |
| NOTE MSS SP-25 gives guidance on marking.  |  |
| 8. Nominal valve size.....   | On body or nameplate or both (where practicable)   |
| a) Full-opening valves: nominal valve size.....  | On body or nameplate or both (where practicable)   |
| b) Reduced-opening valves: shall be marked as specified in 6.2 .....   | On body or nameplate or both (where practicable)   |
| 9. Ring joint groove number .....  | On valve flange edge   |
| 10. SMYS and minimum wall thickness .....  | On body weld bevel ends  |
| 11. Flow direction (for check valves only).....  | On body of uni-directional valves only   |
| 12. Seat sealing direction.....  | Separate identification plate on valve body  |
| 13. Unique serial number .....   | On both body and nameplate   |
| 14. Date of manufacture (month and year).....  | On nameplate   |
| 15. ISO 14313.....   | On nameplate   |



## 11.2 Marking example

To illustrate the requirements for marking specified in this International Standard, a 200 mm carbon steel gate valve with ring joint end flanges, a 664 mm face-to-face dimension, a maximum operating pressure rating of 100 bar, 13% chromium steel trim and manufactured in September 1999 should be marked as follows:

### On body

|        |   |
|--------|---|
| ABCO   | (Item 1: name of manufacturer)                                      |
| PN 100 | (Item 2: pressure class)  |
| WCC    | (Item 5: body material)   |
| DN 200 | (Item 6: nominal valve size)  |
|        | NOTE May also be marked on nameplate or on both body and nameplate. |
| R49    | (Item 9: ring joint identification on flange edge)                  |
| 12345  | (Item 13: serial number)  |

### On bonnet/cover

|       |   |
|-------|---|
| 12345 | (Item 6: bonnet/cover material and melt identification) |
|-------|---|

### On nameplate

|                |   |
|----------------|---|
| ABCO           | (Item 1: manufacturer)  |
| PN 100         | (Item 2: pressure class)  |
| 100 at -29°C   | (Item 3: maximum operating pressure at minimum operating temperature) |
| 90 at 121°C    | maximum operating pressure at maximum operating temperature)          |
| WCC            | (Item 5: body material)   |
| Stem CR13      | (Item 7: trim identification)   |
| Disc CR13      |   |
| Seat CR13      |   |
| or             |   |
| CR13 CR13 CR13 |   |
| or             |   |
| CR13           |   |
| CR13           |   |
| CR13           |   |
| DN 200         | (Item 8: nominal valve size for full-opening valve)                   |
| or             |   |
| DN 200 × 150   | (Item 8: nominal valve size for reduced-bore valve)                   |
| or             |   |
| DN 200R        | (Item 8: nominal valve size for reduced-bore valve)                   |
| 12345          | (Item 13: serial number)  |
| 9-99 or 9/99   | (Item 14: date of manufacture)  |
| ISO 14313      | (Item 15: number of this International Standard)                      |

## 12 Storage and shipping

### 12.1 Painting

All non-corrosion-resistant valves shall be primed and/or painted externally in accordance with the manufacturer's standards, unless otherwise agreed, prior to shipment. Stainless-steel valves shall not be painted unless otherwise agreed. Flange faces, weld bevel ends and exposed stems shall not be painted.

### 12.2 Corrosion prevention

Prior to shipment, parts and equipment which have bare metallic surfaces shall be protected with a rust preventative which will provide protection at temperatures up to 50°C (122°F).

### 12.3 Openings

Valve flanged and welding ends shall be blanked off to protect the gasket surfaces, welding ends and valve internals during shipment and storage. Protective covers shall be made of wood, wood fibre, plastic or metal and shall be securely attached to the valve ends by bolting, steel straps, steel clips or suitable friction-locking devices. The design of the covers shall prevent the valves from being installed unless the covers have been removed.

Plug, ball and reverse-acting through-conduit gate valves shall be shipped in the fully open position, unless fitted with a fail-to-close actuator.

Slab-gate valves shall be shipped with the gate in the fully closed position.

Check valves shall be shipped with the disc supported or secured during transit.

Valves provided with stem extensions without an operating mechanism shall have the annular space closed and the stem extension secured against the outer housing.

## 13 Documentation

The documentation for valves shall include:

- design documentation;
- weld procedure specification (WPS);
- weld procedure qualification record (PQR);
- welder qualification record (WQR);
- qualification records of NDE personnel;
- records of test equipment calibration;
- for valves DN 50 (NPS 2) and larger:
  - melt identification certificates for body bonnet/cover(s) and end connector(s) traceable to the unique valve serial number,
  - serial number for tracing the valve bill of materials,
  - pressure test results.

Documentation shall be provided by the manufacturer in legible, retrievable and reproducible form, and free of damage.

Documentation required by this International Standard shall be retained by the manufacturer for a minimum of five years following the date of manufacture.

The purchaser shall specify which particular supplementary documentation requirements in Annex D shall be provided.

## **Annex A** (informative)

### **Purchasing guidelines**

#### **A.1 General**

This annex provides guidelines to assist the purchaser with valve type selection and specification of specific requirements when ordering valves.

#### **A.2 Field testing**

Pressures during the testing of installed valves should not exceed the pressure rating of the valve by more than 50% when testing with the valve partially open or by more than 10% of the pressure rating when testing against a closed valve.

NOTE The maximum test pressure for valves fitted with an external pressure relief may be lower (see 6.8).

#### **A.3 Pressure relief**

Certain valve designs will trap pressure in the valve body cavity when the valve is in the fully open and/or closed position. High internal pressures can result from the thermal expansion of the fluid trapped in these confined areas. Therefore, if the valve has no self-relieving design provision, pressure relief fittings shall be fitted in the valve body in accordance with 6.8 of this International Standard.

#### **A.4 Pigging**

The purchaser should examine the valve design for compatibility with pigging operations when ordering valves for use in pipelines requiring pigging.

Venturi or reduced-bore valves may not be suitable for pigging operations.

A valve in which the drive member or the obturator obstructs the bore in the otherwise fully open position (e.g. a dual-plate check valve) is not piggable.

Certain full-opening valves with pockets may allow bypass of fluid around a short pig or sphere.

#### **A.5 Fire testing**

The fire resistance design of valves shall be qualified by fire testing in accordance with ISO 10497. Fire resistance designs already qualified to BS 6755 Part 2, API Spec 6FA, API Spec 6FC, API Spec 6FD or API Std 607, third edition, are also acceptable.

#### **A.6 Additional testing**

The purchaser shall specify any additional test requirements not covered by this International Standard.

#### **A.7 Valve data sheet**

The valve data sheet in this annex may be used to assist with the specification of valves for ordering.

**Valve data sheet**

|  |
|--|
| Specification required _____<br>Valve location and function _____<br>Nominal valve size _____<br>Maximum operating pressure _____<br>Maximum field test pressure (see clause A.2) _____<br>Valve pressure class _____<br>Maximum service temperature _____<br>Minimum service temperature _____<br>Liquid or gas service _____<br>Flow medium composition _____<br>Special flow requirements: Blow down, solids, pigs, etc. _____  |
| <p><b>Valve</b></p> Type of valve: Gate _____ Plug _____ Ball _____ Check _____<br>Design type _____<br>Full round opening required? _____ Minimum bore _____  |
| <p><b>End connections</b></p> Upstream pipe: OD _____ ID _____ Material _____<br>Flanged end? Yes _____ No _____<br>Plain raised face or ring joint? _____<br>If ring joint, flat or raised face? _____<br>Size and pressure class, as per ASME B16.5 _____ or MSS SP-44 _____ or ASME B16.47, Series A _____<br>Ring gasket or other gasket type and size _____<br>Note: Gaskets are not furnished as a part of the valve.<br>Welding end? Yes _____ No _____<br>Attach specifications for welding-end configuration.<br>Special flanges or mechanical joints? _____<br>Downstream pipe: OD _____ ID _____ Material _____<br>Flanged end? Yes _____ No _____<br>Plain raised face or ring joint? _____<br>If ring joint, flat or raised face? _____<br>Size and pressure class, as per ASME B16.5 _____ or MSS SP-44 _____ or ASME B16.47, Series A _____<br>Ring gasket or other gasket type and size _____<br>Note: Gaskets are not furnished as a part of the valve.<br>Welding end? Yes _____ No _____<br>Attach specifications for welding-end configuration.<br>Special flanges or mechanical joints? _____<br>Length: Any special requirements for end-to-end or face-to-face dimension? _____ |
| <p><b>Valve operation</b></p> Is gearbox with handwheel required? If so, give details: _____<br>For a handwheel on a horizontal shaft, give distance from centreline of valve opening to handwheel: _____ mm<br>Or, for a handwheel on a vertical shaft, give distance from centreline of valve opening to centre of rim of handwheel: _____ mm<br>Note: For plug valves having loose wrenches, wrenches must be ordered separately.<br>Wrench required? _____<br>Locking device required? _____ Type _____  |
| <p><b>Valve support</b></p> Support ribs or legs required? _____   |
| <p><b>Other requirements</b></p> Supplementary requirements (see Annexes B and C) _____<br>Fire test design? Yes _____ No _____<br>NACE MR 0175? Yes _____ No _____<br>Pressure relief: If pressure relief devices are required, are there special requirements for these devices? _____<br>Drain connections: Any requirements? _____<br>Bypass connections: Any requirements? _____<br>Supplementary documentation required? (See Annex D) _____<br>Third-party witness of processes/testing _____<br>Painting or coating required? _____  |

## **Annex B** **(normative)**

### **Supplementary NDE requirements**

#### **B.1 General**

This annex specifies supplementary NDE requirements for the examination of valves which shall be performed by the manufacturer if specified by the purchaser.

#### **B.2 Radiographic testing of castings on 100% of critical areas in accordance with ASME B16.34**

Examination shall be carried out in accordance with ASME Section V, Article 22. The sensitivity, as indicated by wire penetrometers, shall be 1,5% or better.

Acceptance shall be in accordance with ASME Section VIII, Division 1, Appendix 7. The type and severity level for acceptance of the welding ends shall be as specified by the purchaser.

#### **B.3 Radiographic testing of castings on 100% of accessible areas**

Examination shall be carried out in accordance with ASME Section V, Article 22. The sensitivity, as indicated by wire penetrometers, shall be 1,5% or better.

Acceptance shall be in accordance with ASME Section VIII, Division 1, Appendix 7. The type and severity level for acceptance of the welding ends shall be as specified by the purchaser.

#### **B.4 Ultrasonic testing of castings on 100% of critical areas in accordance with ASME B16.34**

Examination shall be carried out in accordance with ASME Section V, Article 23 using the direct technique or, where proper access or interpretation of results is not possible, by shear wave examination.

Acceptance shall be in accordance with ASTM A 609, Table 2, Quality Level 1.

#### **B.5 Ultrasonic testing of castings on 100% of accessible areas**

Examination shall be carried out in accordance with ASME Section V, Article 23 using the direct technique or, where proper access or interpretation of results is not possible, by shear wave examination.

Acceptance shall be in accordance with ASTM A 609, Table 2, Quality Level 1.

#### **B.6 Magnetic-particle testing of castings on 100% of surface area**

Examination shall be carried out in accordance with ASME Section V, Article 25.

Acceptance shall be in accordance with ASME Section VIII, Division 1, Appendix 6.

**B.7 Liquid penetrant testing of castings on 100% of surface area**

Examination shall be carried out in accordance with ASME Section V, Article 24.

Acceptance shall be in accordance with ASME Section VIII, Division 1, Appendix 8.

**B.8 Ultrasonic testing of forgings and plate on 100% of surface area**

Examination shall be carried out in accordance with ASME Section V, Article 23, or ASTM A 388 or ASTM A 435 or ASTM A 577 as applicable.

Acceptance shall be in accordance with ASME Section VIII, Division 1, Appendix 23, or ASTM A 388 or ASTM A 435 or ASTM A 577 as applicable.

**B.9 Magnetic-particle testing of forgings on 100% of surface area**

Examination shall be carried out in accordance with ASME Section V, Article 25.

Acceptance shall be in accordance with ASME Section VIII, Division 1, Appendix 6.

**B.10 Radiographic testing of weldments on 100% of weld**

Examination shall be carried out in accordance with ASME Section V, Article 22.

Acceptance shall be in accordance with ASME Section VIII, Division 1, Part UW51, for linear indications and ASME Section VIII, Division 1, Appendix 4, for rounded indications.

**B.11 Ultrasonic testing of full-penetration weldments on 100% of weld**

Examination shall be carried out in accordance with ASME Section V, Article 23.

Acceptance shall be in accordance with ASME Section VIII, Division 1, Appendix 12.

**B.12 Magnetic-particle testing of bolting**

Examination shall be carried out in accordance with ASME Section V, Article 25.

Acceptance shall be in accordance with ASME Section VIII, Division 1, Appendix 6.

**B.13 Liquid penetrant testing of bolting**

Examination shall be carried out in accordance with ASME Section V, Article 24.

Acceptance shall be in accordance with ASME Section VIII, Division 1, Appendix 8.

**B.14 Magnetic-particle testing on 100% of machined surfaces**

Examination shall be carried out in accordance with ASME Section V, Article 25.

Acceptance shall be in accordance with ASME Section VIII, Division 1, Appendix 6.

**B.15 Liquid penetrant testing on 100% of machined surfaces**

Examination shall be carried out in accordance with ASME Section V, Article 24.

Acceptance shall be in accordance with ASME Section VIII, Division 1, Appendix 8.

**B.16 Liquid penetrant testing of weld bevels of welding ends**

Examination shall be carried out in accordance with ASME Section V, Article 24.

Acceptance shall be in accordance with ASME Section VIII, Division 1, Appendix 8.

**B.17 Magnetic-particle testing of weld bevels of welding ends**

Examination shall be carried out in accordance with ASME Section V, Article 25.

Acceptance shall be in accordance with ASME Section VIII, Division 1, Appendix 6.





## **Annex C** (normative)

### **Supplementary test requirements**

#### **C.1 General**

This annex defines requirements for supplementary valve testing which shall be performed by the manufacturer if specified by the purchaser. The frequency of testing shall also be specified by the purchaser, if not defined in this annex.

#### **C.2 Hydrostatic testing**

By agreement, hydrostatic testing may be performed at pressures higher than specified in 10.3 and 10.4 and/or for periods longer than specified in Table 9, 10 or 11.

#### **C.3 Low-pressure gas seat testing**

##### **C.3.1 Acceptance**

The acceptable leakage rate for low-pressure gas seat testing shall be:

- ISO 5208 Rate A (no visible leakage) for soft-seated valves;
- ISO 5208 Rate D for metal-seated valves.

##### **C.3.2 Type I**

The seat test specified in 10.4 shall be repeated at a test pressure between 0,5 bar and 1,0 bar gauge (7,3 psig and 14,7 psig) using air or nitrogen as the test medium.

##### **C.3.3 Type II**

The seat test specified in 10.4 shall be repeated at a test pressure of  $5,5 \pm 0,7$  bar gauge ( $80,8$  psig  $\pm 10,3$  psig) using air or nitrogen as the test medium.

#### **C.4 High-pressure gas testing**

The seat tests specified in 10.2 and 10.4 shall be replaced with a high-pressure seat test using an inert gas as the test medium. The test pressure and duration shall be as specified in 10.2 and 10.4.

#### **C.5 Anti-static testing**

The electrical resistance between the obturator and the valve body and between the stem/shaft and the valve body shall be measured using a D.C. power source not exceeding 12 V. The resistance shall be measured on dry valves before pressure testing and shall not exceed 10  $\Omega$ .

At least 5% of the valves in the order shall be tested.

## C.6 Torque/thrust testing

The maximum torque or thrust required to operate ball, gate or plug valves shall be measured at the pressure specified by the purchaser for the following valve operations:

- a) open to closed with the bore pressurized and the cavity at atmospheric pressure;
- b) closed to open with both sides of the obturator pressurized and the cavity at atmospheric pressure;
- c) closed to open with one side of the obturator pressurized and the cavity at atmospheric pressure;
- d) as in c) but with the other side of the obturator pressurized.

Torque or thrust values shall be measured with seats free of sealant except where the sealant is the primary means of sealing. If necessary for assembly, a lubricant with a viscosity not exceeding that of SAE 10W motor oil or equivalent may be used.

Thrust and torque testing shall be performed following hydrostatic shell testing and, if specified, low-pressure gas seat testing.

The measured torque or thrust results shall be compared with the manufacturer's predicted values.

## C.7 Cavity relief testing

### C.7.1 Frequency

Each valve shall be tested.

Cavity relief testing is not required if protection of the cavity against over-pressure is ensured, for both the open and the closed position, by a hole in the obturator or around the seat seal.

### C.7.2 Trunnion-mounted ball valves and through-conduit gate valves with internal-relieving seats

The procedure for cavity relief testing of trunnion-mounted ball valves and through-conduit gate valves with internal-relieving seats shall be:

- a) fill the valve in the half-open position with water;
- b) close the valve and allow water to overflow from the test connection at each end of the valve;
- c) apply pressure to the valve cavity until one seat relieves the cavity pressure into the valve end and record this relief pressure;
- d) for valve types with second-seat relief, continue to increase the pressure to the cavity until the second seat relieves and record the relief pressure of the second seat.

Failure to relieve shall be cause for rejection.

### C.7.3 Floating-ball valves

The procedure for cavity relief testing of floating-ball valves shall be:

- a) with the valve half-open, pressurize the valve to 1,33 times the valve pressure rating specified in 6.1 for the material at 38°C (100°F);
- b) close the valve and vent each end to atmospheric pressure;
- c) open the valve to the half-open position and monitor for the release of test medium trapped in the cavity.

Evidence of trapped pressurizing medium in the cavity shall be cause for rejection.

## **C.8 Hydrogen-induced cracking test**

Process-wetted and pressure-containing parts which are manufactured, fabricated or formed from plate shall be resistant to hydrogen-induced cracking (HIC). This shall be demonstrated by successful HIC testing in accordance with NACE TM 0284, except that the test solution shall comply with NACE TM 0177. HIC acceptance criteria, such as the crack sensitivity ratio (CSR), crack length ratio (CLR) and crack thickness ratio (CTR), shall be specified by the purchaser.



## **Annex D** **(normative)**

### **Supplementary documentation requirements**

The manufacturer shall provide the following supplementary documentation if specified by the purchaser:

- D1) Non-destructive examination (NDE) records
- D2) NACE hardness certification
- D3) Hardness test report on pressure-containing parts
- D4) Certificate of conformance to this International Standard
- D5) Heat treatment certification records (e.g., charts)
- D6) Design calculations for pressure-containing parts and/or the drive train
- D7) Pressure test report, including pressure, test duration and test medium
- D8) NDE personnel qualification records
- D9) Coating/plating certification
- D10) NDE procedures
- D11) Calibration records (purchaser to identify requirements for equipment when ordering)
- D12) Fire test certificate
- D13) Material certification to ISO 10474 (purchaser to specify type of certification, and for which parts, when ordering)
- D14) Design verification by certification body/agency
- D15) Type approval by certification body/agency



## ANNEX E (Informative)

### API MONOGRAM

#### E.0 Introduction

The API Monogram Program allows a licensee to apply the API Monogram to products. Products stamped with the API Monogram provide observable evidence that they were produced in accordance with a verified quality system and in accordance with an API-recognized, international oil and gas industry product specification. The API Monogram Program delivers significant value to the international oil and gas industry by linking the verification of a supplier's quality system with the demonstrated ability to meet specific product specification requirements.

When used in conjunction with the requirements of the API License Agreement, API Specification Q1 Parts One and Two define the program for voluntary licensing of suppliers who wish to provide oil and gas industry products in accordance with an API-recognized international oil and gas industry product specification.

API Monogram Program Licenses are issued only after an on-site audit has verified that the licensee conforms with both the quality system requirements described in API Specification Q1 Part One and the requirements of an API-recognized international oil and gas industry product specification.

For information on becoming an API Monogram Licensee, please contact API at 1220 L Street, N. W., Washington, DC 20005 or call 202-682-8000.

#### E.1 Scope

This Annex sets forth the API Monogram Program requirements necessary for a supplier to consistently produce products in accordance with API specified requirements

#### E.2 References

In addition to the referenced standards listed in Section 2, this Annex references the following standard:

API Specification Q1

For licensees under the Monogram Program, where cited these requirements are mandatory. Referenced standards used by the manufacturer may be either the applicable revision shown in Section 2 and herein, or the latest revision.

#### E.3 API Monogram Program: Licensee responsibilities

**E.3.1** The requirements for all suppliers desiring to acquire and maintain a license to use the API Monogram shall include:

- a) The quality system requirements of API Specification Q1, Part One.
- b) The API Monogram Program requirements of API Specification Q1, Part Two.
- c) The requirements contained in API recognized product specifications.
- d) The requirements contained in the API License Agreement.

**E.3.2** When a licensed supplier is providing monogrammed product, Parts One and Two of API Specification Q1 are mandatory.

**E.3.3** Each Licensee shall control the application of the monogram in accordance with the following:

- a) The Licensee shall apply the monogram, license number, and date of manufacture to monogrammed products in accordance with a marking procedure as specified by the applicable API product specification. Where there are no API product specification marking requirements, the licensee shall define the location(s) where this information is applied.
- b) The monogram may be applied at any time appropriate to the manufacturing process but shall be removed if the product is subsequently found to be in nonconformance with API specified requirements. Products determined to be nonconforming to API specified requirements shall not bear the API monogram.
- c) Only an API Licensee may apply its monogram.
- d) The monogram shall be applied at the licensed facility.
- e) The authority responsible for applying and removing the API monogram shall be defined.

**E.3.4** Records required by API product specifications shall be retained for the period of time specified therein. Records specified to demonstrate achievement of the effective operation of the quality system shall be maintained for a minimum of 5 years.

## **E.4 Marking requirements**

These marking requirements apply only to those API licensees wishing to mark their products with the API Monogram.

**E.4.1** Manufacturers shall mark equipment on the nameplate with “API 6D”, in addition to the marking requirements of Item 15 in Table 12 of Section 11.1.

**E.4.2** As a minimum, equipment should be marked with English (Imperial) Units.

**E.4.3** The API Monogram shall be marked on the nameplate, in addition to the marking requirements of Section 11.1. For valves smaller than DN 50 (NPS 2), the nameplate shall not be omitted, but may be attached to the valve with stainless steel wire.

## **E.5 API Monogram Program: API responsibilities**

The API shall maintain, without references to licensees or users, records of reported problems encountered with API monogrammed products produced in accordance with API Specification Q1 and API product standards.

## **E.6 API Monogram Program: User responsibilities**

The effectiveness of the API monogram program can be strengthened by user reporting problems encountered with API monogrammed products to the API. API solicits information on both new product nonconformance with API specified requirements and field failures (or malfunctions) which are judged to be caused by either specification deficiencies or nonconformance with API specified requirements. Users are requested to report to API problems encountered with API monogrammed products.



## Bibliography

- [1] ISO 5211:—<sup>1)</sup>, *Industrial valves—Part-turn actuator attachments*.
- [2] API Spec 6D, *Pipeline valves (gate, plug, ball, and check valves), twenty-first edition, March 1994*.
- [3] API Spec 6FA, *Fire test for valves*.
- [4] API Spec 6FC, *Fire test for valves with automatic backseats*.
- [5] API Spec 6FD, *Fire test for check valves*.
- [6] API Std 607, *Fire test for soft-seated quarter-turn valves, third edition, November 1985*.  
(American Petroleum Institute, 1220 L Street Northwest, Washington, DC 20005-4070, USA)
- [7] BS 5500, *Specification for unfired fusion welded pressure vessels*.
- [8] BS 4515, *Specification for welding of steel pipelines on land and offshore*.
- [9] BS 6755 Part 2, *Testing of valves—Specification for fire type-testing requirements*.  
(British Standards Institution, 389 Chiswick High Road, London W4 4AL, UK)
- [10] MSS SP-25, *Standard marking system for valves, fittings, flanges and unions*

---

1) To be published. (Revision of ISO 5211-1:1977, ISO 5211-2:1979 and ISO 5211-3:1982)



# 2002 Publications Order Form

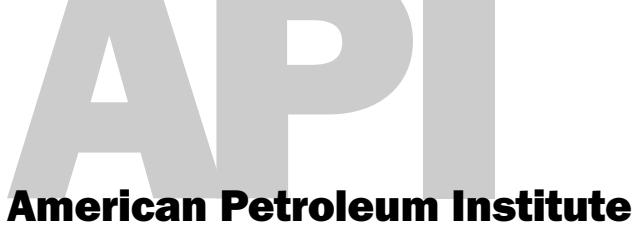

Available through Global Engineering Documents.

Effective January 1, 2002.

**Phone Orders: 1-800-854-7179** (Toll-free in the U.S. and Canada)  
**303-397-7956** (Local and International)  
**Fax Orders: 303-397-2740**  
**Online Orders: www.global.ihs.com**

Date: \_\_\_\_\_

**API Member** (Check if Yes)

**Invoice To** ( Check here if same as "Ship To")

Name: \_\_\_\_\_  
 Title: \_\_\_\_\_  
 Company: \_\_\_\_\_  
 Department: \_\_\_\_\_  
 Address: \_\_\_\_\_  
 \_\_\_\_\_  
 City: \_\_\_\_\_ State/Province: \_\_\_\_\_  
 Zip/Postal Code: \_\_\_\_\_ Country: \_\_\_\_\_  
 Telephone: \_\_\_\_\_  
 Fax: \_\_\_\_\_  
 E-Mail: \_\_\_\_\_

**Ship To** (UPS will not deliver to a P.O. Box)

Name: \_\_\_\_\_  
 Title: \_\_\_\_\_  
 Company: \_\_\_\_\_  
 Department: \_\_\_\_\_  
 Address: \_\_\_\_\_  
 \_\_\_\_\_  
 City: \_\_\_\_\_ State/Province: \_\_\_\_\_  
 Zip/Postal Code: \_\_\_\_\_ Country: \_\_\_\_\_  
 Telephone: \_\_\_\_\_  
 Fax: \_\_\_\_\_  
 E-Mail: \_\_\_\_\_

| Quantity | Product Number | Title  | SO★ | Unit Price       | Total |
|----------|----------------|--|-----|------------------|-------|
|          | <b>G05B14</b>  | <b>Spec 5B, Threading, Gauging, and Thread Inspection of Casing, Tubing, and Line Pipe Threads</b> |     | <b>\$ 110.00</b> |       |
|          | <b>G05L42</b>  | <b>Spec 5L, Line Pipe</b>  |     | <b>\$ 165.00</b> |       |
|          | <b>G06A17</b>  | <b>Spec 6A, Wellhead and Christmas Tree Equipment</b>  |     | <b>\$ 165.00</b> |       |
|          | <b>G06FA3</b>  | <b>Spec 6FA, Fire Test for Valves</b>  |     | <b>\$ 66.00</b>  |       |
|          | <b>G06FC3</b>  | <b>Spec 6FC, Fire Test for Valve with Automatic Backseats</b>                                      |     | <b>\$ 66.00</b>  |       |
|          | <b>G06FD1</b>  | <b>Spec 6FD, Fire Test for Check Valves</b>  |     | <b>\$ 61.00</b>  |       |
|          | <b>C60700</b>  | <b>Std 607, Fire Test for Soft-seated Quarter-turn Valves</b>                                      |     | <b>\$ 46.00</b>  |       |

**Payment Enclosed**     **P.O. No.** (Enclose Copy) \_\_\_\_\_

**Charge My Global Account No.** \_\_\_\_\_

**VISA**     **MasterCard**     **American Express**     **Diners Club**     **Discover**

Credit Card No.: \_\_\_\_\_

Print Name (As It Appears on Card): \_\_\_\_\_

Expiration Date: \_\_\_\_\_

Signature: \_\_\_\_\_

|  |  |
|--|--|
| <b>Subtotal</b>                          |  |
| <b>Applicable Sales Tax</b> (see below)  |  |
| <b>Rush Shipping Fee</b> (see below)     |  |
| <b>Shipping and Handling</b> (see below) |  |
| <b>Total (in U.S. Dollars)</b>           |  |

★ *To be placed on Standing Order for future editions of this publication, place a check mark in the SO column and sign here:*

**Pricing and availability subject to change without notice.**

**Mail Orders** – Payment by check or money order in U.S. dollars is required except for established accounts. State and local taxes, \$10 processing fee\*, and 5% shipping must be added. Send mail orders to: **API Publications, Global Engineering Documents, 15 Inverness Way East, M/S C303B, Englewood, CO 80112-5776, USA.**

**Purchase Orders** – Purchase orders are accepted from established accounts. Invoice will include actual freight cost, a \$10 processing fee\*, plus state and local taxes.

**Telephone Orders** – If ordering by telephone, a \$10 processing fee\* and actual freight costs will be added to the order.

**Sales Tax** – All U.S. purchases must include applicable state and local sales tax. Customers claiming tax-exempt status must provide Global with a copy of their exemption certificate.

**Shipping (U.S. Orders)** – Orders shipped within the U.S. are sent via traceable means. Most orders are shipped the same day. Subscription updates are sent by First-Class Mail. Other options, including next-day service, air service, and fax transmission are available at additional cost. Call 1-800-854-7179 for more information.

**Shipping (International Orders)** – Standard international shipping is by air express courier service. Subscription updates are sent by World Mail. Normal delivery is 3-4 days from shipping date.

**Rush Shipping Fee** – Next Day Delivery orders charge is \$20 in addition to the carrier charges. Next Day Delivery orders must be placed by 2:00 p.m. MST to ensure overnight delivery.

**Returns** – All returns must be pre-approved by calling Global's Customer Service Department at 1-800-624-3974 for information and assistance. There may be a 15% restocking fee. Special order items, electronic documents, and age-dated materials are non-returnable.

**\*Minimum Order** – There is a \$50 minimum for all orders containing hardcopy documents. The \$50 minimum applies to the order subtotal including the \$10 processing fee, excluding any applicable taxes and freight charges. If the total cost of the documents on the order plus the \$10 processing fee is less than \$50, the processing fee will be increased to bring the order amount up to the \$50 minimum. This processing fee will be applied before any applicable deposit account, quantity or member discounts have been applied. There is no minimum for orders containing only electronically delivered documents.

# There's more where this came from.

The American Petroleum Institute provides additional resources and programs to the oil and natural gas industry which are based on API Standards. For more information, contact:

- Monogram Licensing Program Phone: 202-962-4791  
Fax: 202-682-8070
- American Petroleum Institute Quality Registrar (APIQR) Phone: 202-962-4791  
Fax: 202-682-8070
- API Spec Q1 Registration Phone: 202-962-4791  
Fax: 202-682-8070
- Perforator System Registration Phone: 202-962-4791  
Fax: 202-682-8070
- Inspector Certification Programs Phone: 202-682-8161  
Fax: 202-962-4739
- Engine Oil Licensing and Certification System (EOLCS) Phone: 202-682-8233  
Fax: 202-962-4739
- Training/Workshops Phone: 202-682-8490  
Fax: 202-962-4797

Check out the API Publications, Programs, and Services Catalog online at [www.api.org](http://www.api.org).





Additional copies are available through Global Engineering Documents at (800) 854-7179 or (303) 397-7956

Information about API Publications, Programs and Services is available on the World Wide Web at: <http://www.api.org>



1220 L Street, Northwest  
Washington, D.C. 20005-4070  
202-682-8000

Product No. G06D22